

# IA504D

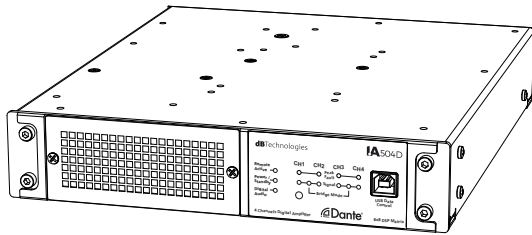

## DIMENSIONS

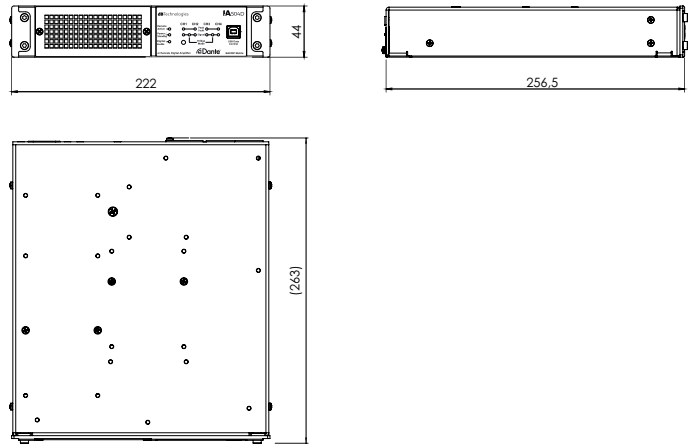

## MAIN FEATURES

- 4 channels digital amplifier for passive speakers
- Powerful DSP
- Compact half rack size
- Quick installation
- AURORA Net control
- Multiple configuration options
- two Dante® networking ports

## DESCRIPTION

IA504D is the new dBTechnologies professional amplifier for passive speakers with integrated Dante® interface for a remote in-depth control and configuration using AURORA NET software. The device is equipped with a powerful amplifier section, capable of handling up to 500 W (RMS power) in 4 channels and controlled by a DSP, which can perform a detailed customization of the output of the speakers. The mechanical design allows an easy, accurate and quick installation in half, 1U rack or flat surface thanks to the optional brackets. In addition, the user can load presets for dBTechnologies passive speakers using AURORA NET software to provide an excellent listening experience.

## PACKAGE CONTENTS

The box contains:

- n.1 IA504D amplifier
- n.1 mains cable
- n.3 Euroblock 3.81mm connectors
- n.2 Euroblock 5.08mm connectors

This quick start and warranty documentation

## ACCESSORIES

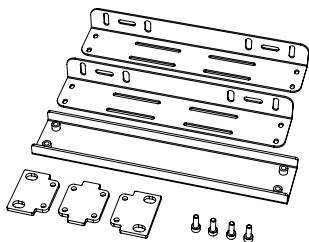

RMK-1  
rack and surface mount kit

## SPECIFICATIONS

Amplifier Type	4 channels digital amplifier - half rack
Frequency Response [±0.5dB]	20 - 20000 Hz
Amplifier Gain	31 dB
Signal to Noise Ratio	>103 dB(A)
Input Sensitivity	+4 dBu
Crosstalk	100 dB
Maximum Input Level	+18 dBu
Input Impedance	20 kOhm
Amplifier	Class-D
Power Supply	Full-range SMPS
Cooling	Fan forced (front to back)
Operating Range	100-240V~ (50-60Hz)
RMS Out Power single channel	280 W @ 4 Ω, 245 W @ 8 Ω 135 W @ 16 Ω, 280 W @ 8 Ω (bridge) 250 W @ 70V, 240 W @ 100V
Peak Power single channel	425 W @ 4 Ω, 245 W @ 8 Ω, 135 W @ 16 Ω, 619 W @ 8 Ω (bridge)
RMS Out Power 4 channels	70 W @ 4 Ω, 70 W @ 8 Ω, 70 W @ 16 Ω, 140 W @ 8 Ω (bridge), 140 W @ 70V, 140 W @ 100V
Peak Power 4 channels	225 W @ 4 Ω, 180 W @ 8 Ω, 125 W @ 16 Ω, 440 W @ 8 Ω (bridge)
Limiter	Dual Active Peak, RMS, Thermal
Controller	32 bit DSP
AD/DA Converter	24 bit/48 kHz
Control	Reset button
Signal Input connector	Euroblock 3.81mm
Signal Output connector	Euroblock 5.08mm
Ethernet connectors	Dante® ETH1/ETH2
USB connector	USB B-type (for DATA CONTROL)
Dimensions (WxHxD)	222x44x256 mm (8.7x1.7x10.1 in)
Weight	1.82 Kg (4.01 lbs.)

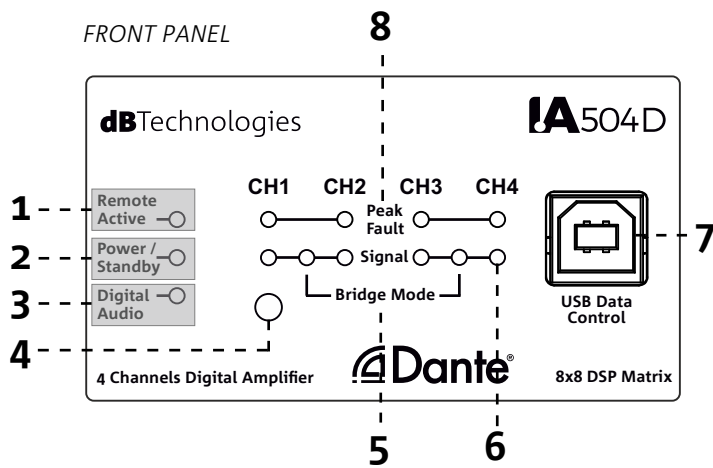

**I/O AND CONTROL PANEL**

The amplifier is controlled by a powerful DSP. All the connections, except USB Data control, are in the rear amplifier control panel.

- 1- Remote Active LED
- 2- Power/Standby LED
- 3- Digital Audio LED
- 4- Reset button
- 5- Bridge Mode LED
- 6- Signal LED
- 7- USB Data Control
- 8- Peak Fault LED
- 9- Analog/digital audio Inputs
- 10- GPIO/Standby ports
- 11- Ethernet RJ45 ports
- 12- Power Outputs
- 13- Full-range Mains Input

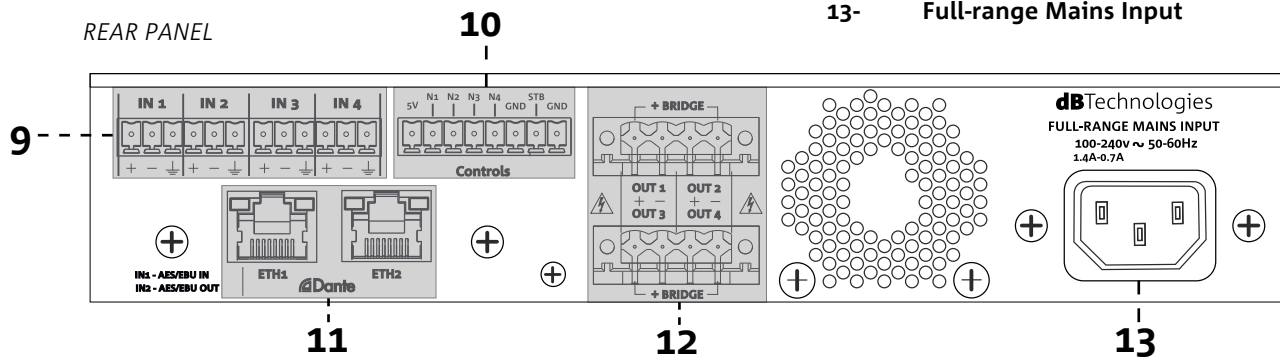

**POWER SUPPLY SPECIFICATIONS (POWER ABSORPTION)**

Draw at 1/8 of full power in average use conditions (\*): 0.36 A (220-240V~) - 0.66 A (100-120V~)

Draw at 1/3 of full power in average use conditions (\*\*): 0.7 A (220-240V~) - 1.4 A (100-120V~)

Power absorption with speaker turned on without signal (idle): 0,16 A (220-240V~) - 0.25 A (100-120V~)

*\*INSTALLER NOTES: The values refer to 1/8 of full power, in average operating conditions (music program with infrequent or no clipping). It is recommended to consider them the minimum sizing values, for any type of configuration.*

*\*\*INSTALLER NOTES: The values refer to 1/3 of full power, in heavy operating conditions (music program with frequent clipping or activation of the limiter. We recommend sizing according to these values in case of professional installations and tours.*

**INPUT SETTINGS**

**Balanced analog signal**

Connect the positive and negative pole, and the ground of the input signal to the corresponding input on the amplifier.

**Balanced digital signal**

IN1 and IN2 can be set as AES/EBU digital I/O; open AURORA NET software and set IN1 and IN2 as digital sources then connect the positive and negative pole, and the ground. More details in AURORA NET SETTINGS chapter.

**Unbalanced analog signal**

Connect the positive pole and the ground of the input signal to the corresponding input on the amplifier.

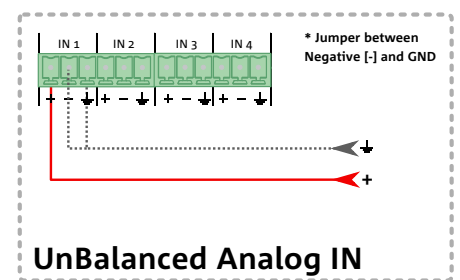
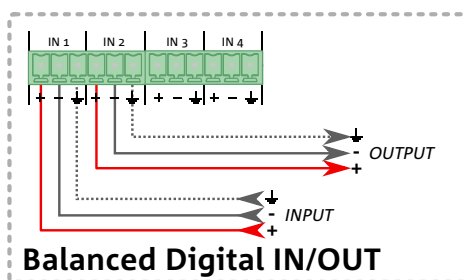
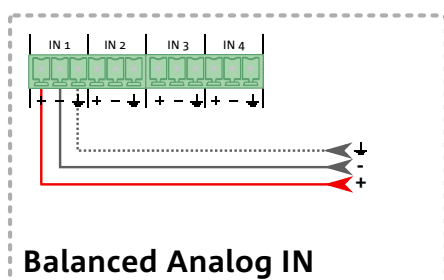

## OUTPUT SETTINGS

### Stereo setup

Connecting a pair of speakers in stereo mode. Recall the correct setup from the software AURORA NET in the Setup => Output section. The minimum impedance must be 4 Ohms.

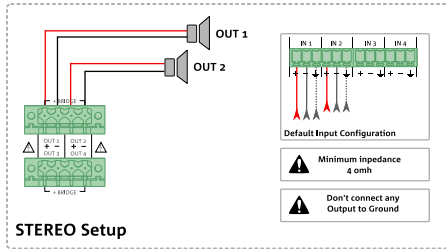

### Bridge setup

Connecting a speaker in bridge mode. Recall the correct setup from the software AURORA NET in the Setup => Output section. The minimum impedance must be 8 Ohms.

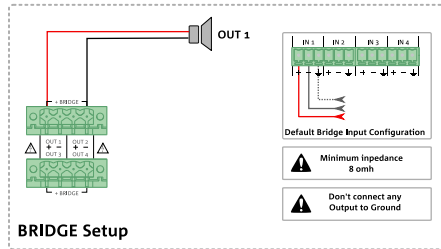

### 70/100V setup

Connecting speakers in 70/100V mode. Recall the correct setup from the software AURORA NET in the Setup => Output section.

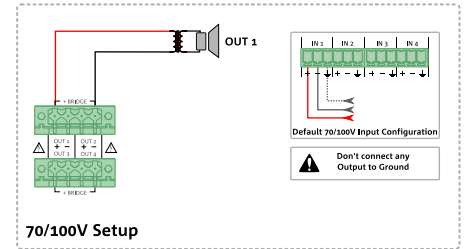

## AURORA NET SETTINGS

For a quick setup connect a PC/Mac to the amplifier using a USB cable, download and open AURORA NET software\* and click on Setup section (Fig.1) and then on Configure button. From the Output Settings page that will open up (Fig.2), the user can adjust the output mode between different choices. Click on the Load button to load presets for dBTechnologies passive speakers (Fig.3).

To set the input 1-2 as AES/EBU digital I/O click on the button INPUT 1-2 ANALOG.

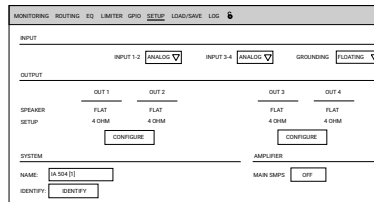

Fig.1

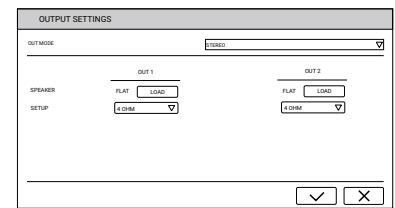

Fig.2

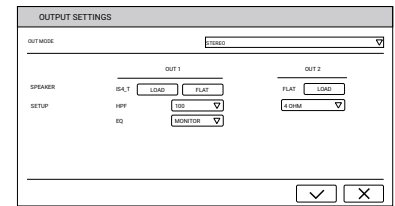
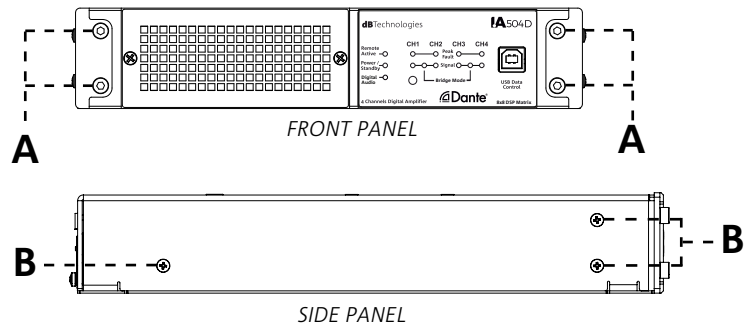

Fig.3

\*please be sure to download the latest version of the software. Check it on [www.dbtechnologies.com](http://www.dbtechnologies.com)

## INSTALLATION

IA504D can be installed in different configurations. For a quick installation, on the front of the amplifier (A) the user can find mechanical fixing point for rack mounting. On each side (B) of the amplifier the user can find mechanical fixing point for wall/flat surface mounting.



### RACK MOUNT

### SURFACE MOUNT

N.1 AMP  
IN A HALF RACK

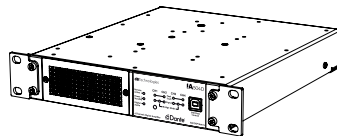

N.2 AMPS  
IN ONE RACK

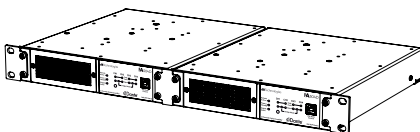

N.1 AMP  
IN ONE RACK

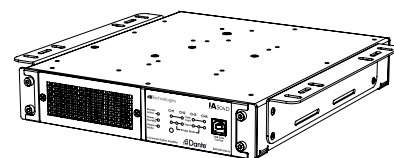
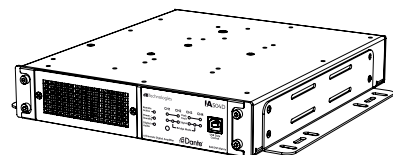
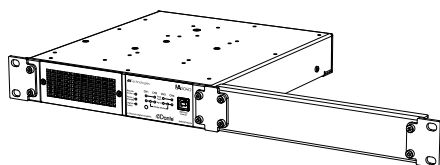

## NETWORK SETUP

Connect your dBTechnologies Dante™ device, PC or Mac running Dante™ Controller and AuroraNet over an Ethernet network using at least CAT5e shielded cables up to 100m (for longer distances an optical fiber interface is required).

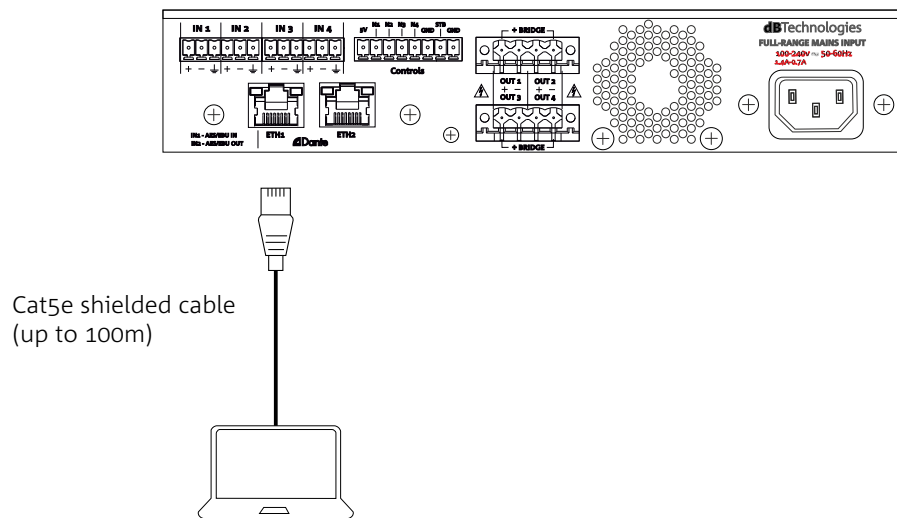

Using a network switch allows to connect up to 4 dBTechnologies devices in daisy chain configuration for each port; use more network switches to connect multiple devices. Please use a good quality Gigabit switch that supports Diffserv (DSCP) and quality of service (QOS). For more information refer to Audinate website.

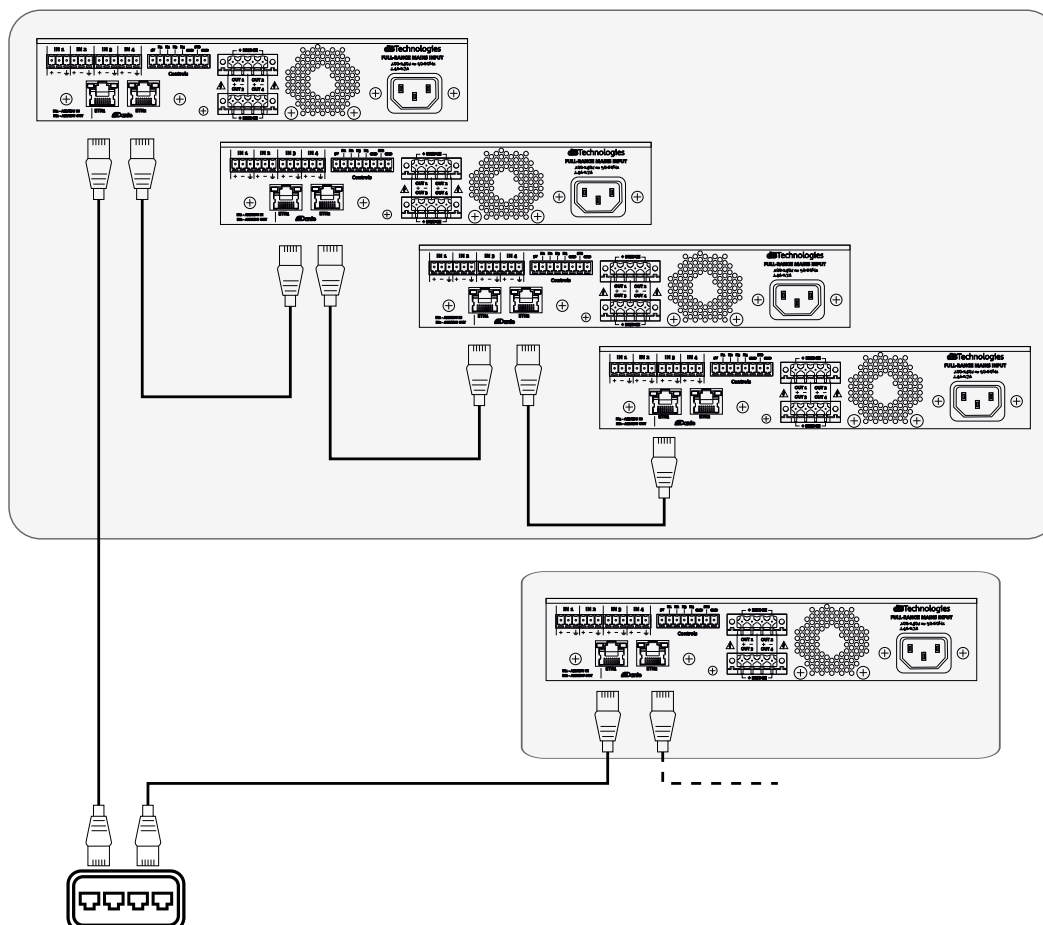

In case any specific network configurations or preferences have to be made (e.g. fixed IP address), these settings have to be adjusted through the Dante controller software tool.

## IMPORTANT NOTES AND WARNINGS

### EMI CLASSIFICATION

According to the standards EN 55032 and 55035 this is a class B equipment, designed and suitable to operate in residential environments.

### FCC CLASS B STATEMENT ACCORDING TO TITLE 47, PART 15, SUBPART B, §15.105

This equipment has been tested and found to comply with the limits for a Class B digital device, pursuant to part 15 of the FCC Rules.

These limits are designed to provide reasonable protection against harmful interference in a residential installation.

This equipment generates, uses and can radiate radio frequency energy and, if not installed and used in accordance with the instructions, may cause harmful interference to radio communications.

However, there is no guarantee that interference will not occur in a particular installation. If this equipment does cause harmful interference to radio or television reception, which can be determined by turning the equipment off and on, the user is encouraged to try to correct the interference by one or more of the following measures:

1. Reorient or relocate the receiving antenna.
2. Increase the separation between the equipment and receiver.
3. Connect the equipment into an outlet on a circuit different from that to which the receiver is connected.
4. Consult the dealer or an experienced radio/TV technician for help.

Changes or modifications not expressly approved by the party responsible for compliance could void the user's authority to operate the equipment.



### WARNINGS!

Make sure that the device is securely installed in a stable position to avoid any injuries or damages to persons or properties. Before installing the device check all the components for damages, deformations, missing or damaged parts that may compromise safety during installation. Follow the instructions contained in this quick start user manual and on the complete user manual to properly install the device. It's suggested to keep enough distance from other devices to allow the right cooling.

*The warnings in this manual must be observed in conjunction with the "USER MANUAL - Section 2".*

*Features, specification and appearance of products are subject to change without notice. dBTechnologies reserves the right to make changes or improvements in design or manufacturing without assuming any obligation to change or improve products previously manufactured.*

The external wiring connected to speaker output terminals requires installation by qualified personnel only. Once the equipment is installed, prevent access to the connectors to unqualified personnel. Only use the accessories and configurations described in this manual, and proceed in accordance with the instructions given in the manuals for the accessories.

Only use the power cable provided.

The USB SERVICE DATA connection is to be used exclusively for updating the product's firmware; do not connect any other USB device to the unit to avoid the risk of damage and malfunction.

Check periodically the integrity and the functionality of the accessories and the technical equipments for a safe installation. User should never apply a load that exceeds the working load limits of any rigging components or equipment here presented. Design, calculation, installation, testing and maintenance of suspension and stack systems for audio equipment must be performed only by qualified and authorized personnel. AEB Industriale s.r.l. denies any and all responsibility for improper installations, in the absence of safety requirements.





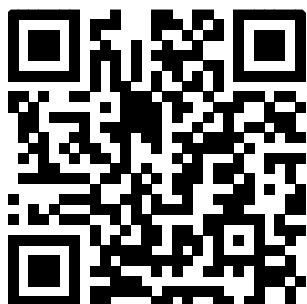

*Scan with your  
QR Reader App  
to download the  
complete User  
Manual.*



A.E.B. Industriale Srl  
Via Brodolini, 8  
Località Crespellano  
40053 VALSAMOGGIA  
BOLOGNA (ITALIA)  
Tel. +39 051 969870  
Fax +39 051 969725  
[www.dbtechnologies.com](http://www.dbtechnologies.com)  
[info@dbtechnologies-aeb.com](mailto:info@dbtechnologies-aeb.com)