

# VIO X315

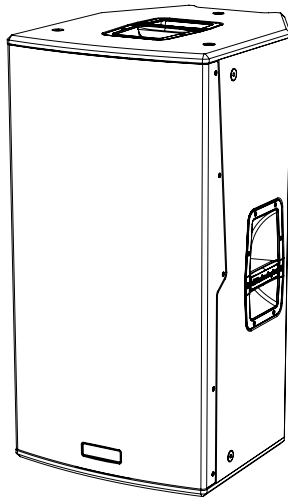

## DIMENSIONS

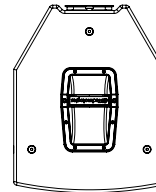
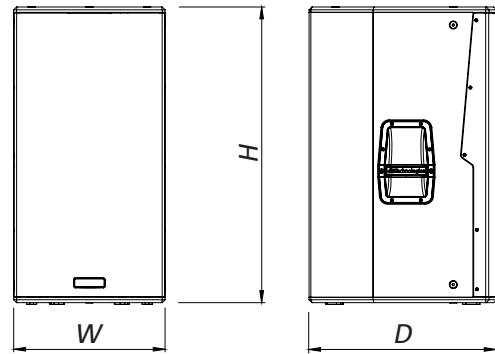

<b>W</b>	<b>420mm (16.5 in)</b>
<b>H</b>	<b>820mm (32.3 in)</b>
<b>D</b>	<b>520mm (20.5 in)</b>

## MAIN FEATURES

- Modular point source system
- Impressive sound pressure
- New powerful amplifier
- Quick installation
- Easy handling and transport
- Stack or flyable use
- AURORA Net control

## PACKAGE CONTENTS

The box contains:

- N°1 VIO X315 loudspeaker
- N°1 mains cable
- N°1 fuse for 100-120Vac power supply
- N°1 transport cover
- This quick start and warranty documentation

## DESCRIPTION

VIO X315 is the new dB Technologies 3-way active speaker for professional use. It is equipped with: one coaxial neodymium transducer (MF voice coil: 4", HF voice coil: 2,5", HF exit: 1.4") and a 15" neodymium woofer (4" voice coil). The coverage pattern is 90° (H) x 50° (V) (5° tilted down). The horn is rotatable and the mechanical design allows an easy, accurate and quick installation for stand or flyable use. The powerful DigiPro G4 amplifier section, capable of handling up to 1400 W (RMS power), is controlled by a DSP, which can perform a detailed customization of the output sound of the speaker. In addition, the integrated RDNet connections are useful for a remote in-depth control and configuration using AURORA NET software.

## TECHNICAL SPECIFICATIONS

Speaker Type	3 Way Active Loudspeaker
Frequency Response [-6dB]	37 - 18.000 Hz
Usable Bandwith [-10dB]	34 - 19.200 Hz
Max SPL (1 m)	137 dB
Directivity (HxV)	90° x 50° (5° tilted down)
HF	4" - 2.5" coax neodymium, 1.4" exit
LF	15" neodymium, 4" v.c.
Crossover Frequency	550 Hz (LF - MF), 4 kHz (MF -HF) 24 dB/oct
Amplifier	Digipro® G4 1400 W RMS Class-D (4 channels)
Power Supply	Full-range SMPS with PFC
Cooling	Passive (convection)
Operating Range	220-240V~ (50-60Hz)/100-120V~ (50-60 Hz)
Limiter	Peak, RMS, Thermal
Processing	FIR Linear Phase Filters
Controller	32 bit DSP
AD/DA Converter	24 bit/96 kHz
Controls	1x Rotary Encoder (8x EQ presets) 1x Ready LED 1x Mute/Prot LED 1x Signal LED 1x Limiter LED 1x System Test button
Signal Input	1 x XLR balanced, 1 x RJ45 Link (RDNet), 1x USB (Data Service)
Signal Output	1x XLR balanced, 1 x RJ45 Link (RDNet)
Housing	Wooden box - black finished
Rigging Points	4
Dimensions (WxHxD)	420x820x520 mm (16.5x32.3x20.5 in)
Weight	39.5 Kg (87.1 lbs.)

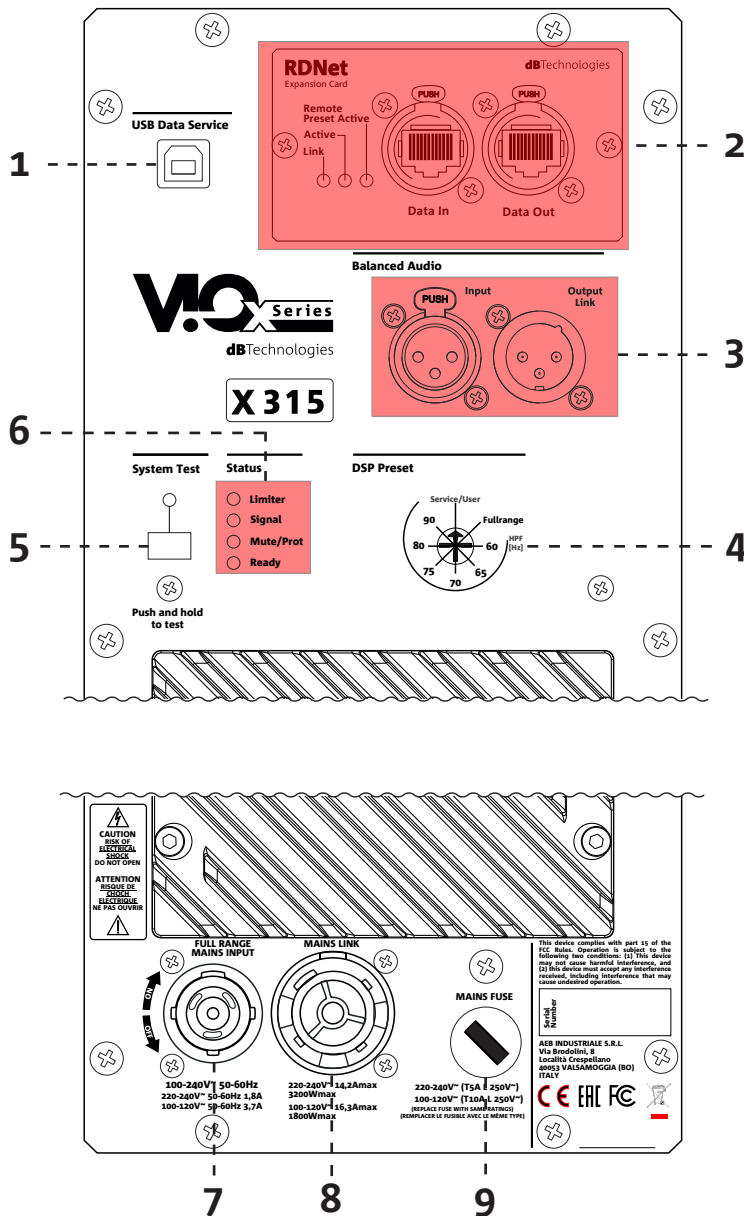

**I/O and Control panel**

The DigiPro G4 amplifier of VIO X315 is controlled by a powerful DSP. All the connections and controls are in the rear amplifier control panel.

- 1- B-type USB port for firmware updating
- 2- RDNet Data In / Data Out and Control LEDs
- 3- Balanced audio input and output link
- 4- DSP Preset rotary switch (High Pass Filter)
- 5- System Test
- 6- Status LEDs (Limiter, Signal, Mute/Protection, Ready)
- 7- Full-range Mains input
- 8- Mains Link output
- 9- Mains Fuse

**Setup, turn on and I/O settings**

Connect first the audio input (1); to link the audio signal to another speaker, please use a cable with XLR connectors (not supplied). Connect the Output Link of the first, to the balanced Input of the second one, and so on.

Plug properly the mains POWERCON TRUE1 cable (supplied) in the related input (7) to turn on the system. To supply power to another speaker connect the Mains Link output of the first speaker to the Mains Input of the second one and so on. To find out how many modules can be connected in a linked system, refer to the "TECHNICAL SPECIFICATIONS" or "CONNECTIONS" sections in the VIO X315 user manual.

In case of remote control, connect the Data Input of the speaker to the hardware remote controller (RDNet Control 2 or RDNet Control 8) with cables equipped with etherCON connectors. Connect the Data Output of the first, to the Data Input of the second one, and so on. When the speaker is active and the RDNet network is active and it has recognized the connected device, the LED Link is on. The "Active" LED start blinking when there is the presence of data trasmission, the "Remote Preset Active" advise that all the local controls set on the amplifier panel (DSP preset) are by-passed and controlled remotely by RDNet.

See also RDNet Control 2 or RDNet Control 8 user manuals for further information.

**POWER SUPPLY SPECIFICATIONS (POWER ABSORPTION)**

Draw at 1/8 of full power in average use conditions (\*): 0,8 A (220-240V~) - 1,5 A (100-120V~)

Draw at 1/3 of full power in maximum use conditions (\*\*): 1,8 A (220-240V~) - 3,7 A (100-120V~)

Power absorption with speaker turned on without signal (idle): 0,25 A (220-240V~) - 0,28 A (100-120V~)

\*INSTALLER NOTES: The values refer to 1/8 of full power, in average operating conditions (music program with infrequent or no clipping). It is recommended to consider them the minimum sizing values, for any type of configuration.

\*\*INSTALLER NOTES: The values refer to 1/3 of full power, in heavy operating conditions (music program with frequent clipping or activation of the limiter. We recommend sizing according to these values in case of professional installations and tours

### HANDLES

On the top and on the side of the loudspeaker the user can find three handles for easy handling (A).

### MECHANICAL FIXING POINT

VIO X315 can be installed in different configurations. For a quick installation on each side of the loudspeaker the user can find mechanical fixing point for flyable use with M10 eyebolt (B). The loudspeakers is also equipped with a pole mount on the bottom (C).

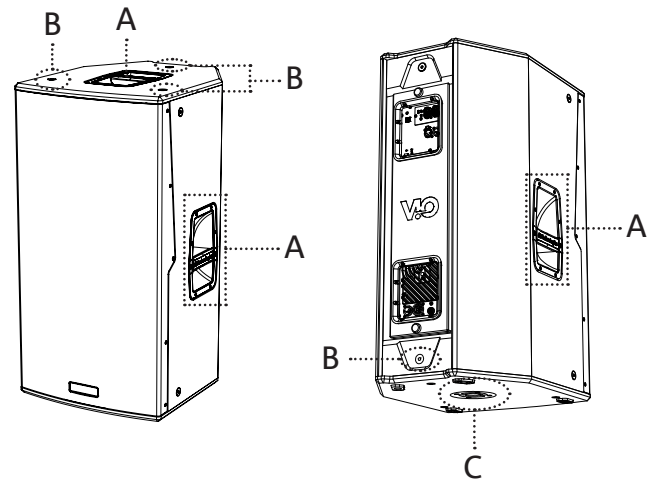

## CONFIGURATIONS

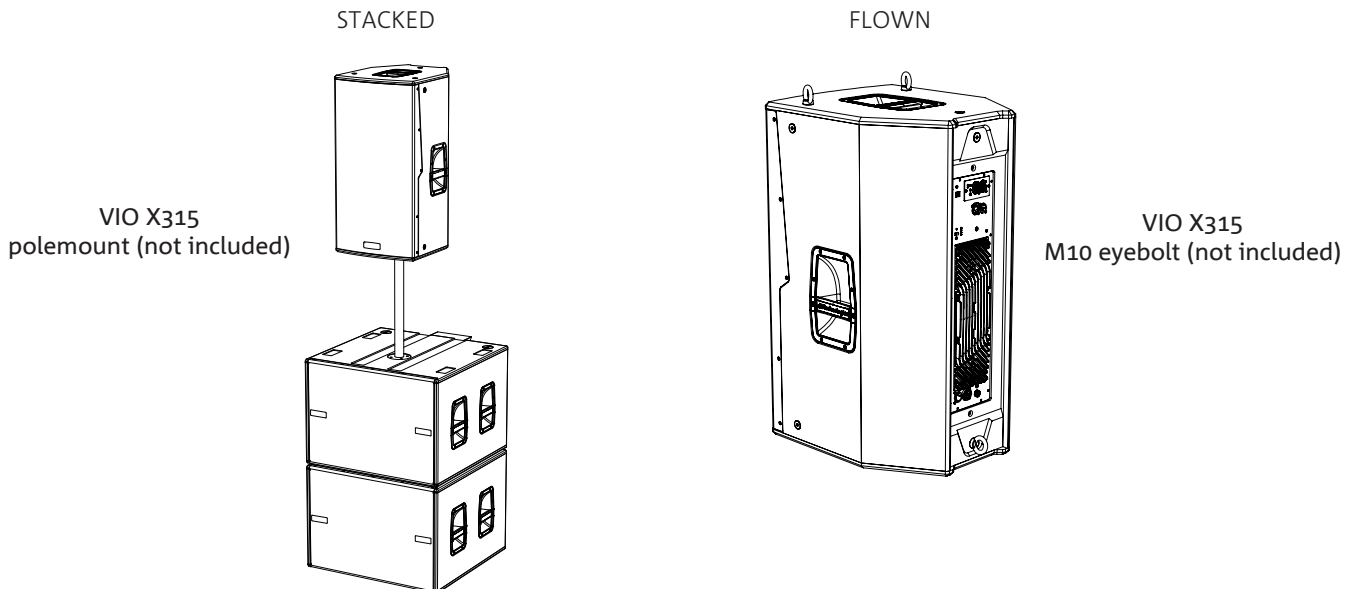

## IMPORTANT NOTES AND WARNINGS

### EMI CLASSIFICATION

According to the standards EN 55032 and 55035 this is a class A equipment, designed and suitable to operate in residential environments.

### FCC CLASS A STATEMENT ACCORDING TO TITLE 47, PART 15, SUBPART B, §15.105

This equipment has been tested and found to comply with the limits for a Class A digital device, pursuant to part 15 of the FCC Rules. These limits are designed to provide reasonable protection against harmful interference when the equipment is operated in a commercial environment. This equipment generates, uses, and can radiate radio frequency energy and, if not installed and used in accordance with the instruction manual, may cause harmful interference to radio communications. Operation of this equipment in a residential area is likely to cause harmful interference in which case the user will be required to correct the interference at his own expense.

**WARNING:** Make sure that the loudspeaker is securely installed in a stable position to avoid any injuries or damages to persons or properties.

For safety reasons do not place one loudspeaker on top of another without proper fastening systems. Before hanging the loudspeaker check all the components for damages, deformations, missing or damaged parts that may compromise safety during installation. If you use the loudspeakers outdoor avoid spots exposed to bad weather conditions.

Contact dB Technologies for accessories to be used with speakers. dBTechnologies will not accept any responsibility for damages caused by inappropriate accessories or additional devices.

*Features, specification and appearance of products are subject to change without notice.*

*dBTechnologies reserves the right to make changes or improvements in design or manufacturing without assuming any obligation to change or improve products previously manufactured.*

**IMPORTANT SAFETY INSTRUCTIONS**

1. Read these instructions
2. Keep these instructions.
3. Heed all warnings.
4. Follow all instructions.
5. Do not use this apparatus near water.
6. Clean only with dry cloth.
7. Do not block any ventilation openings. Install in accordance with the manufacturer's instructions.
8. Do not install near any heat sources such as radiators, heat registers, stoves, or other apparatus (including amplifiers) that produce heat.
9. Do not defeat the safety purpose of the polarized or grounding-type plug. A polarized plug has two blades with one wider than the other. A grounding type plug has two blades and a third grounding prong. The wide blade or the third prong are provided for your safety. If the provided plug does not fit into your outlet, consult an electrician for replacement of the obsolete outlet.
10. Protect the power cord from being walked on or pinched particularly at plugs, convenience receptacles, and the point where they exit from the apparatus.
11. Only use attachments/accessories specified by the manufacturer.
12. Use only with the cart, stand tripod, bracket, or table specified by the manufacturer, or sold with the apparatus. When a cart is used, use caution, when moving the cart/apparatus combination to avoid injury from tip-over.
13. Unplug this apparatus during lightning storms or when unused for long periods of time.
14. Refer all servicing to qualified service personnel. Servicing is required when the apparatus has been damaged in any way, such as power-supply cord or plug is damaged, liquid has been spilled or objects have fallen into the apparatus the apparatus has been exposed to rain or moisture, does not operate normally, or has been dropped.

**ADDITIONAL SAFETY INSTRUCTIONS**

- No naked flame sources, such as lighted candles, should be placed on the apparatus
- Do not use the apparatus in tropical climates

**WARNINGS!**

Only expert personnel may use the product and its accessories! To prevent hazards to people, animals and/or objects, make sure that the installation is stable and secure. Comply with the safety regulations and laws in force in the country in which you use the product. For safe use, periodically check that all parts are in good working condition before use. Only authorised personnel may carry out design, calculations, installation, testing and maintenance of professional flown or stacked audio systems. AEB Industriale shall not be liable for improper installation carried out without adequate safety measures.

Never suspend the speakers from the handles! Only use the accessories and configurations described in this manual, and proceed in accordance with the instructions given in the manuals for the accessories.

Do not obstruct the amplifier cooling fins at the back. In the event of overheating, the audio volume is gradually reduced until the module is thermally stable. The level is automatically restored on reaching the correct operating temperature.

Do not attempt to open the amplifier.

In the event of malfunction, immediately turn off the power, disconnect the unit from the mains and contact an authorised service centre.

Only use the power cable provided.

The USB SERVICE DATA connection is to be used exclusively for updating the product's firmware; do not connect any other USB device to the unit to avoid the risk of damage and malfunction.

Do not use the monitor for a prolonged period with the limiter LED steadily lit or flashing as this indicates operation under stress with excessive distortion.

Check periodically the integrity and the functionality of the accessories and the technical equipments for a safe installation. user should never apply a load that exceeds the working load limits of any rigging components or equipment here presented. design, calculation, installation, testing and maintenance of suspension and stack systems for audio equipment must be performed only by qualified and authorized personnel. AEB Industriale s.r.l. denies any and all responsibility for improper installations, in the absence of safety requirements.

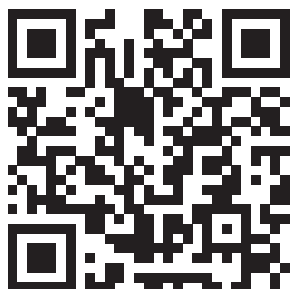

*Scan with your  
QR Reader App  
to download the  
complete User  
Manual.*

A.E.B. Industriale Srl  
Via Brodolini, 8  
Località Crespellano  
40053 VALSAMOGGIA  
BOLOGNA (ITALIA)  
Tel. +39 051 969870  
Fax +39 051 969725

[www.dbtechnologies.com](http://www.dbtechnologies.com)  
[info@dbtechnologies-aeb.com](mailto:info@dbtechnologies-aeb.com)