

## CONTENTS

<b>1</b>	PACKAGE CONTENTS	16
<b>2</b>	MECHANICAL/ACOUSTIC FEATURES	17
<b>3</b>	CONFIGURATION OPTIONS	17
<b>4</b>	SPEAKER CONTROL PANEL	18
<b>5</b>	SUBWOOFER CONTROL PANEL	20
<b>6</b>	POWER SUPPLY	22
<b>7</b>	QUICK SETUP	23
<b>8</b>	ACCESSORIES	24
<b>9</b>	EXAMPLES OF INSTALLATION	24
<b>10</b>	TROUBLESHOOTING	25
<b>11</b>	SPEAKER TECHNICAL DATA	26
<b>12</b>	SUBWOOFER TECHNICAL DATA	28

**1 PACKAGE CONTENTS**

- 1 x Speaker/subwoofer series R
- 1 x User manual - Section 1
- 1 x User manual - Section 2
- 1 x Power cable specific for your area of use

Thank you for purchasing a product created by Montarbo, an Italian company founded in 1962, always at the service of music and professional audio. Montarbo products, original and avant-garde, are designed with the utmost attention to detail and durability. Reliability is in line with the high quality standards and sensitivity to environmental impact that distinguish the company.

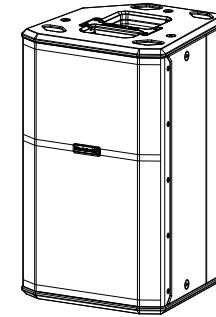

The R series active speakers are professional, versatile, ergonomic. The line includes speakers and subwoofers, and is therefore suitable for PA use in various contexts. The multiple I/Os enhance their versatility. A DSP with 4 presets adapts the acoustic performance to different conditions of use.

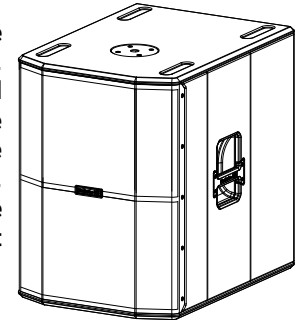
**2 MECHANICAL/ACOUSTIC FEATURES**

The speakers are equipped with a compression driver for high frequencies (voice coil: 1.35" for R108-110, 1.75" for R112-115) and an 8", 10", 12", and 15" transducer for R108, R110, R112 and R115 respectively. The mechanical design integrates 3 handles, as well as a pole mounting flange (on the bottom). In addition to this, two sides of the cabinet, with 40° inclination, allow use as a stage monitor. The subwoofers have a 15" (R15S) and 18" (R18S) woofer with 4" voice coil respectively. From a mechanical point of view, the subwoofers, in addition to an M20 adapter on the upper side that allows the mounting of a speaker on a pole (not supplied), are prepared for fixing an optional wheel kit to facilitate handling. Finally, for each model there are optional covers for safe transport and rapid weather protection.

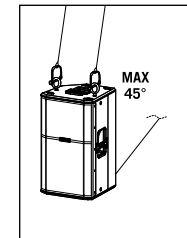
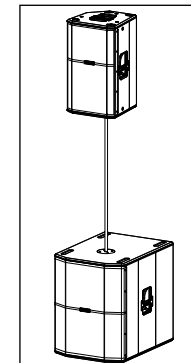
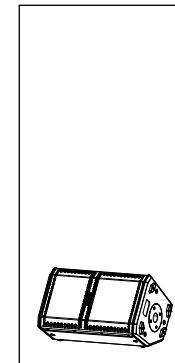
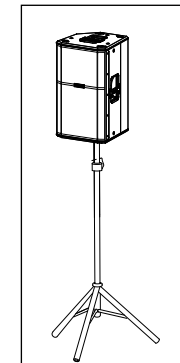
**3 CONFIGURATION OPTIONS**

FOR FURTHER INFORMATION  
SEE CHAPTER 9

The warnings in this manual must be observed in conjunction with the "USER MANUAL - Section 2".

## 4 SPEAKER CONTROL PANEL

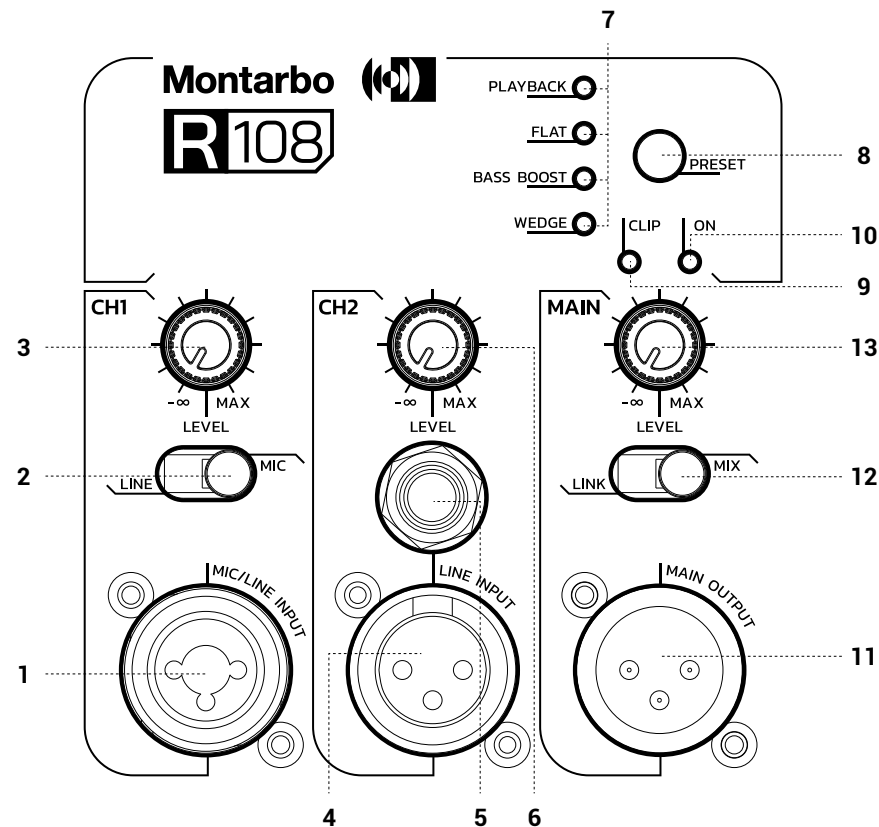

### 1 MIC/LINE INPUT

6.35 mm XLR/jack combo input for microphone and line signals.

### 2 LINE/MIC SELECTOR SWITCH

This selector switch can be used to adjust the input sensitivity.

### 3 CH1 LEVEL

This knob adjusts the level of channel 1, turn it to the right to raise the level, to the left to lower it.

### 4 LINE INPUT

Input for line level signals with XLR-F connector.

### 5 LINE INPUT

Input for line level signals with 6.35 mm jack connector.

### 6 CH2 LEVEL

This knob adjusts the level of channel 2, turn it to the right to raise the level, to the left to lower it.

### 7 PRESET LED

These LEDs indicate which preset is active between PLAYBACK, FLAT, BASS BOOST and WEDGE.

These presets have been optimized for different applications. PLAYBACK is ideal for listening to recorded audio and/or karaoke, FLAT is great for concerts, BASS BOOST is perfect for playing rich low frequency audio, such as DJing and disco music, while WEDGE is for use as a stage monitor.

### 8 PRESET

This button allows you to choose the optimal preset for your current application from the four presets.

### 9 CLIP LED

This LED lights up when the speaker signal is close to distortion. In this case reduce both the MAIN signal and the active channels signal.

### 10 ON LED

This LED lights up when the speaker is connected to the mains and the power switch is ON.

### 11 MAIN OUTPUT

This XLR-M output provides a balanced line level signal, its signal is set by its selector switch.

### 12 LINK/MIX

Through this selector you can choose whether the output signal to another speaker must be the one present in the inputs (LINK) or the one mixed between the three input channels and controlled by the MAIN (MIX).

### 13 MAIN LEVEL

This knob adjusts the output level of the active speaker.

## 5 SUBWOOFER CONTROL PANEL

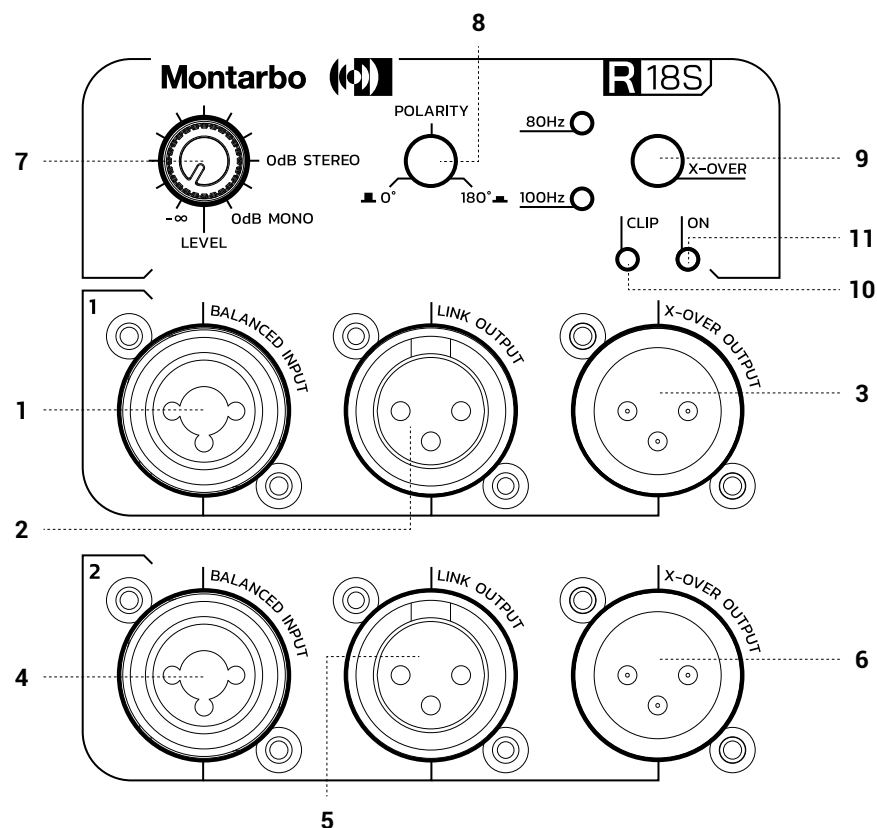

### 1 CH1 BALANCED INPUT

6.35mm XLR/jack combo input for microphone and line signals.

### 2 CH1 LINK OUTPUT

Line output for audio signal link.

### 3 CH1 X-OVER OUTPUT

Crossover output for linking the audio signal to one head (speaker)

### 4 CH2 BALANCED INPUT

6.35mm XLR/jack combo input for microphone and line signals.

### 5 CH2 LINK OUTPUT

Line output for audio signal link.

### 6 CH2 X-OVER OUTPUT

Crossover output for linking the audio signal to one head (speaker)

### 7 LEVEL

This knob adjusts the output level, turn it to raise the level or lower it. In particular the positions at 0 dB are indicated in the case of single system (INPUT 1) or stereo (INPUT 1 + INPUT 2).

### 8 POLARITY

If pressed, it allows you to invert the polarity (180°), which is normally in the 0° position.

### 9 X-OVER

Allows you to choose the crossover frequency for linking the signal to one head. Pressing the key in succession enables one or the other cut-off frequency (80 Hz/100 Hz).

### 10 CLIP LED

This LED lights up when the subwoofer signal is close to distortion. In this case reduce both the MAIN signal and the active channels signal.

### 11 ON LED

This LED lights up when the subwoofer is connected to the mains and the power switch is ON.

## 6 POWER SUPPLY

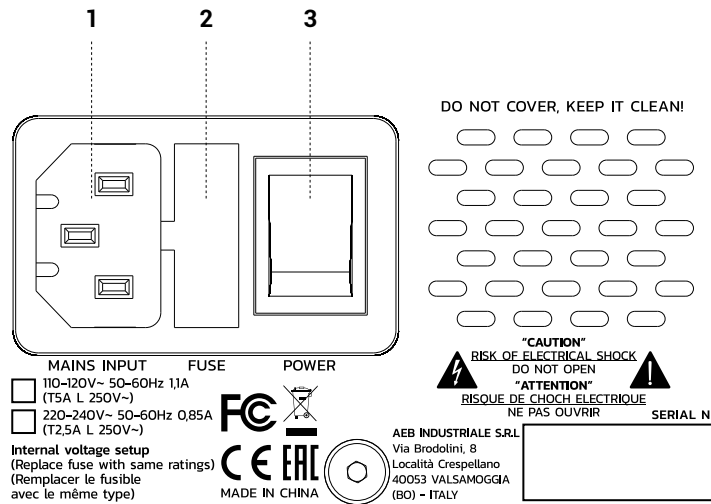

### 1 MAINS INPUT

IEC input socket with integrated mains filter. Each package is supplied with the necessary power cable, specific for your area. With the speaker off, plug the power cable into this socket. For your own safety, never disconnect the ground contact.

### 2 FUSE

Protection fuse.

**CAUTION:** Only replace the fuse with one of the same type and with the same rating. If the fuse keeps blowing, contact an authorised service centre.

### 3 POWER ON/OFF

Switch for switching the active speaker on/off.

## 7 QUICK SETUP

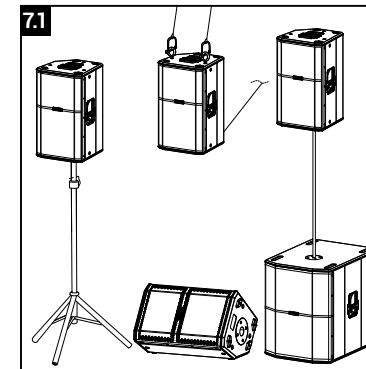

Place the speaker according to the chosen installation

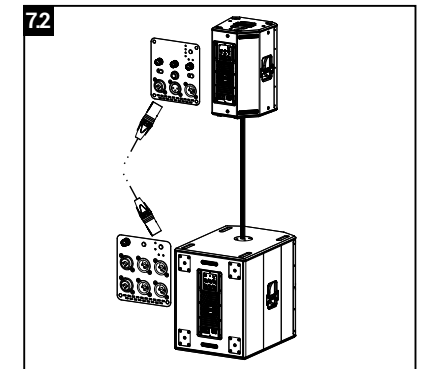

Assemble and connect any speaker-subwoofer groups

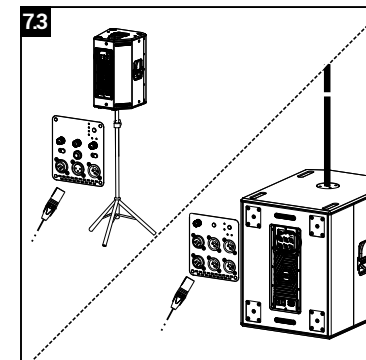

Connect the audio sources to the inputs (channel levels at zero)

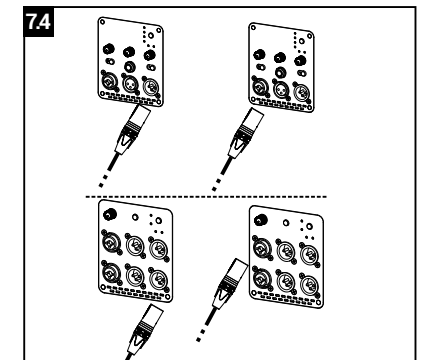

Make any further links

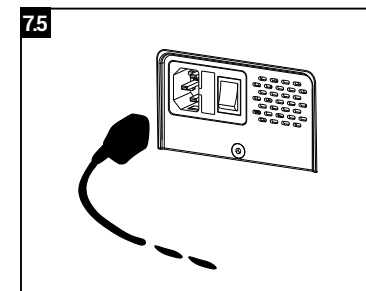

Insert the power cables and switch on

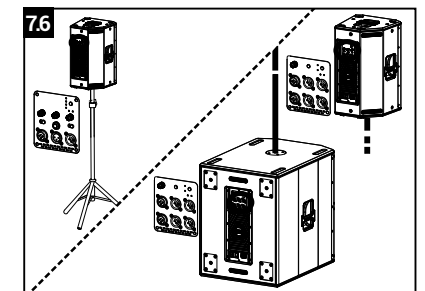

Adjust all volumes (and any crossovers) as desired

## 8 ACCESSORIES

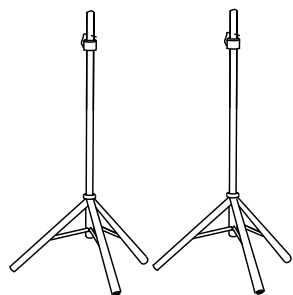

Pair of tripods

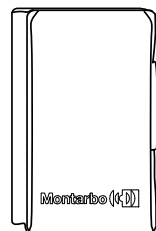
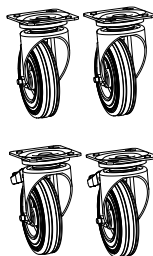
CV-R108/R110/R112/R115/R15S/R18S  
coverKit of 4 wheels  
for subwoofers

## 9 EXAMPLES OF INSTALLATION

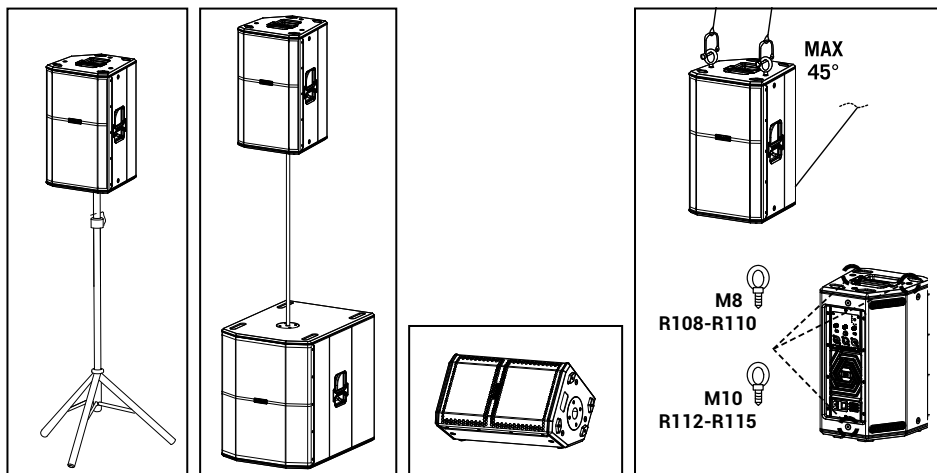

### INSTALLATION OF A SPEAKER ON A TRIPOD STAND

The speaker can be installed on an optional standard tripod stand with 35 mm diameter pole. The maximum permissible height between the speaker base and the floor is 170 cm for R108, R110, R112 and 150 cm for R115. Any other use requires additional fixing (not supplied).

### INSTALLATION OF A WEDGE SPEAKER

The speaker can be positioned, using the angle of the cabinet, as a live monitor. In this case, we recommend selecting the WEDGE preset on the control panel.

### INSTALLATION OF A SPEAKER ON A SUBWOOFER WITH POLE

By using the prearrangement on the top of the subwoofer, it is possible to screw on a standard

pole for mounting a speaker on a subwoofer. In this case the maximum permissible height between the base of the speaker and the floor also depends on the supporting subwoofer. With R18S: 180 cm (R108-R110) or 150 cm (R112-R115). With R15S: 170 cm (R108), 150 cm (R110-R112), 120 cm (R115). These heights refer to the alignment of the sub front and speaker front. Any other configuration requires additional fixing (not supplied). In the case of a subwoofer - speaker link, select the possible crossover.

### INSTALLATION WITH EYEBOLTS

The speaker can also be installed using eyebolts. The positioning is shown in the figure on the side, where the rear eyebolt allows adjusting the final angle (MAX 45°).

Positioning is intuitive. For amplifying to a seated or standing audience, the use of certified stands is recommended, placed on a flat surface and with power and signal cables placed so that they cannot be walked on, are not stretched and cannot present a risk of tripping or poor safety.

## 10 TROUBLESHOOTING

### The speaker/subwoofer does not power up

- Check that there is a correct power supply upstream from the system.
- Check that the power cable with VDE connector is plugged in properly.

### The speaker/subwoofer powers up but does not emit any sound

- Check that the connections to the audio channel inputs (CH1, CH2) are correct.
- Check that the cables used are not interrupted. Use only quality cables in good condition.
- Check that the audio sources are switched on and show an output signal.
- Check that the input sensitivity of CH1 (for speakers) is correct.
- Check the volume of the MAIN (speaker) or LEVEL (subwoofer) output.

### The speaker/subwoofer emits low or distorted sound:

- Adjust the appropriate source volume for the mixer section inputs.
- Check that the cables used are not damaged. Use only quality cables in good condition.
- Check the volume level of the inputs and the MAIN (or LEVEL for the subwoofer).
- Lower the level of the MIC, LINE and/or MAIN inputs.
- Make sure you have not connected a line signal to channel 1 with MIC sensitivity.
- Check the crossover filter cuts, in case of a subwoofer-speaker link

### Presence of background noise

- Turn off the power and disconnect all connected devices.
- Check the signal from all sources to find out which one caused the problem.

## II SPEAKER TECHNICAL DATA

MODEL	R 108	R 110	R 112	R 115
TYPE	2-way bass reflex	2-way bass reflex	2-way bass reflex	2-way bass reflex
MAX SPL (@ 1m)	125 dB	127 dB	131 dB	132 dB
Frequency response (-10 dB)	63 Hz – 20 kHz	61 Hz – 20 kHz	51 Hz – 20 kHz	48 Hz – 20 kHz
Frequency response (-6 dB)	71 Hz – 19 kHz	66 Hz – 19 kHz	56 Hz – 19 kHz	54 Hz – 19 kHz
HF	1.35" driver	1.35" driver	1.75" driver	1.75" driver
LF	8" - 2" V.C	10" - 2" V.C	12" - 3" V.C	15" - 3" V.C
Crossover frequency	1800 Hz	1780 Hz	1500 Hz	1450 Hz
Coverage (H x V)	90°x70°	90°x70°	90°x40°	90°x40°
Amplification class	D + A/B	D + A/B	D	D
RMS power	200 W	200 W	600 W	600 W
Peak power	400 W	400 W	1200 W	1200 W
Cooling	Fan	Fan	Passive radiator	Passive radiator
Operating voltage	110-120V~ 50-60Hz 220-240V~ 50-60Hz	110-120V~ 50-60Hz 220-240V~ 50-60Hz	110-120V~ 50-60Hz 220-240V~ 50-60Hz	110-120V~ 50-60Hz 220-240V~ 50-60Hz
Operating ambient temperature	-20° +45°	-20° +45°	-20° +45°	-20° +45°
DSP	28/56 bit	28/56 bit	28/56 bit	28/56 bit
Advanced functions	FIR filters	FIR filters	FIR filters	FIR filters
AD/DA converter	24 bit, 48 kHz	24 bit, 48 kHz	24 bit, 48 kHz	24 bit, 48 kHz

I/O connectors	CH1: Combo CH2: XLR-F + 6.35 mm jack (1/4") LINE OUT: XLR-M	CH1: Combo CH2: XLR-F + 6.35mm jack (1/4") LINE OUT: XLR-M	CH1: Combo CH2: XLR-F + 6.35 mm jack (1/4") LINE OUT: XLR-M	CH1: Combo CH2: XLR-F + 6.35mm jack (1/4") LINE OUT: XLR-M
Controls	Channel level MAIN level PRESET Channel 1 sensitivity LINK/MIX output	Channel level MAIN level PRESET Channel 1 sensitivity LINK/MIX output	Channel level MAIN level PRESET Channel 1 sensitivity LINK/MIX output	Channel level MAIN level PRESET Channel 1 sensitivity LINK/MIX output
Fuse	T5A L – 100-120V~ T2.5A L - 220-250V~	T5A L – 100-120V~ T2.5A L - 220-250V~	T6.3A L – 100-120V~ T3.15A L - 220-250V~	T6.3A L – 100-120V~ T3.15A L - 220-250V~
Consumption at 1/8 of the power (medium conditions of use)	0.6 A (110-120V~) 0.39 A (220-240V~)	0.6 A (110-120V~) 0.39 A (220-240V~)	1.47 A (110-120V~) 0.89 A (220-240V~)	1.47 A (110-120V~) 0.89 A (220-240V~)
Consumption at 1/3 of the power (maximum conditions of use)	1.1 A (110-120V~) 0.85 A (220-240V~)	1.1 A (110-120V~) 0.85 A (220-240V~)	3 A (110-120V~) 1.8 A (220-240V~)	3 A (110-120V~) 1.8 A (220-240V~)
Consumption in stand-by	18 W	18W	18W	18W
Inrush current	9.5 A	9.5 A	4 A	4 A
Cabinet material	Multilayer wood with polyurea finish	Multilayer wood with polyurea finish	Multilayer wood with polyurea finish	Multilayer wood with polyurea finish
Dimensions (W x H x D)	264 x 440 x 260 mm 10.4" x 17.3" x 10.3"	304 x 505 x 305 mm 11.9" x 19.9" x 14.4"	359 x 610 x 350 mm 14.2" x 24" x 13.8"	427 x 705 x 428 mm 16.8" x 27.8" x 16.9"
Weight	10.9 kg (24 lbs)	12.7 kg (28 lbs)	21 kg (46,3 lbs)	25.9 kg (57 lbs)
MODEL	R 108	R 110	R 112	R 115

## ▣ SUBWOOFER TECHNICAL DATA

MODEL	R15S	R18S
TYPE	Vented – stereo sub	Vented – stereo sub
MAX SPL (@ 1m)	130 dB	131.5 dB
Frequency response (-10 dB)	45 Hz – Cut freq	41 Hz – Cut freq
Frequency response (-6 dB)	48 Hz – Cut freq	44 Hz – Cut freq
LF	15" - 4" V.C	18" - 4" V.C
Amplification class	D	D
RMS power	500 W	500 W
Peak power	1000 W	1000 W
Cooling	Passive radiator	Passive radiator
Operating voltage	110-120V~ 50-60Hz 220-240V~ 50-60Hz	110-120V~ 50-60Hz 220-240V~ 50-60Hz
Operating ambient temperature	-20° +45°	-20° +45°
DSP	28/56 bit	28/56 bit
AD/DA converter	24 bit, 48 kHz	24 bit, 48 kHz
I/O connectors	CH1/CH2: Combo LINE OUT: XRL-M (LINK+XOVER)	CH1/CH2: Combo LINE OUT: XRL-M (LINK+XOVER)

Controls	LEVEL XOVER selection POLARITY selection	LEVEL XOVER selection POLARITY selection
Fuse	T8A H – 100-120V~ T4A L - 220-250V~	T8A H – 100-120V~ T4A L - 220-250V~
Consumption at 1/8 of the power (medium conditions of use)	1.5 A (110-120V~) 0.9 A (220-240V~)	1.5 A (110-120V~) 0.9 A (220-240V~)
Consumption at 1/3 of the power (maximum conditions of use)	1.7 A (110-120V~) 3 A (220-240V~)	1.7 A (110-120V~) 3 A (220-240V~)
Consumption in stand-by	19 W	19 W
Inrush current	5.7 A	5.7 A
Cabinet material	Multilayer wood with polyurea finish	Multilayer wood with polyurea finish
Dimensions (W x H x D)	430 x 580 x 590 mm 16.9" x 22.8" x 23.2"	510 x 650 x 690 mm 20" x 25.6" x 27.2"
Weight	31.9 kg (70.32 lbs)	38 kg (83.8 lbs)
MODEL	R15S	R18S