

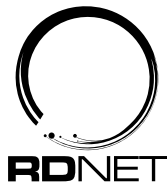

Digital Vertical Array



The global group of dBTechnologies companies develops and manufactures individual speaker components autonomously, and often specifically for the given application. We do not subscribe to the practice of equalizing and optimizing speakers with elaborate technology to bring them up to our standards. Instead, it has been our long-standing policy to build from the bottom up components with specs tailored to deliver the best audio performance for the application.

**DVA T12** is a step up the evolutionary ladder from the successful DVA T4 line array system. Although it provides more power and has greater range, its active three-way design makes it just as **easy to set up and install as its predecessor**.

# T12

## Full of Technology

- LONG-THROW SYSTEM
- FULLY POWERED THREE-WAY UNIT  
FREELY SCALABLE TO SETUPS OF ANY SIZE
- LOSSLESS SIGNAL PATH WITH NO NEED FOR SPEAKER CABLES
- SEQUENTIALLY CONFIGURABLE ARRAY SEGMENTS
- HIGH-END DIGITAL CONTROLLER (DSP) ON BOARD
- NETWORK-READY WITH AN INTEGRATED RDNET PORT
- HARDWARE COMPATIBLE WITH DVA T8 SYSTEMS
- NONE OF THE IMPEDANCE AND AMP CHANNEL AVAILABILITY CONCERNS ASSOCIATED WITH PASSIVE MODELS

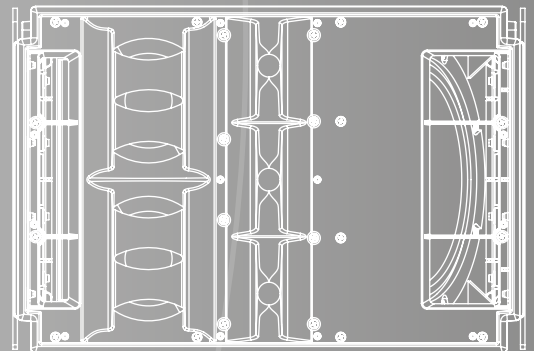

**dB**Technologies

# 3-Way Active Line Array Module

## DVA T12

### Technical Data

Speaker Type: 3-Way Active Line Array Module

### Acoustical data

Frequency Response [+/- 3dB]: 60 - 19.000 Hz

Max SPL: One Unit: 136 dB

HF: 3x1 "

Voice Coil HF: 1.4 "

Directivity: 100x10° Single unit

Horn: Integrated CD Horn

MF: 2x 6.5 "

Type MF: Neodymium Sealed Basket Phase Plug Horn Loaded

Voice Coil MF: 2 "

LF: 12 "

Type LF: Neodymium

Voice Coil LF: 3 "

### Amplifier

Amp Technology: Digipro® G2

Amp Class: Class D

HF Amp: 350 W RMS

MF Amp: 350 W RMS

LF Amp: 710 W RMS

Cooling: Convection

### Processor

Controller: DSP 56 bit

AD/DA Converter: 24 bit/96 kHz

System Presets: 8, HF/Low-mid correction

Limiter: Dual Active Limiter Multiband RMS, Peak, Thermal

Crossover Frequency MF-HF: 1800 Hz

Slope MF-HF: 24 dB/Octave

Crossover Frequency LF-MF: 420 Hz

Slope LF-MF: 24 dB/Octave

### Input

Signal Input: 1x XLR fem, Bal.

Signal Output: 1x XLR male, Bal.

Network: RDnet remote control RJ45 connector IN/OUT

Power Socket: 1x Powercon In 1x Powercon Out

Voltage Range: 90 - 240 V

### Mechanics

Housing: Polypropylen PP Aluminium reinforced

Housing Design: Trapezoidal 10°

Rain cover: Included

Rigging Points: Integrated rigging hardware

Width: 580 mm (23.2 in)

Height: 386 mm (15.44 in)

Depth: 430 mm (17.2 in)

Weight: 29,9 kg (63.93 lbs)

**The DVA T12** features state-of-the-art neodymium speakers and high-performance digital amps with total of 1,410W output power. In combination with top-drawer DSP and premium quality AD-DA converter, it delivers high-definition sonic images with massive SPL for large sound reinforcement applications.



**Weighing just 29kg**, this remarkably compact unit belies its unobtrusive look by enabling you to set up very powerful line arrays that deliver extraordinary performance.



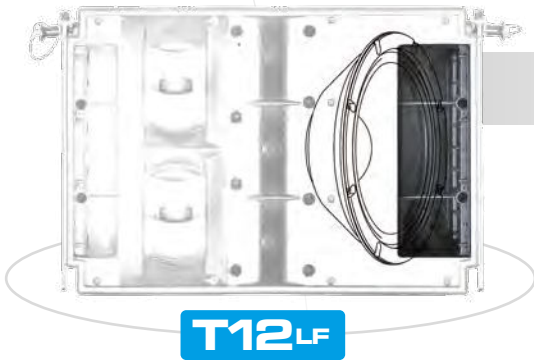

### **Extended low-end performance**

A 12" neodymium woofer in a band-pass housing covers the low frequency range. Remarkably powerful, it packs an assertive punch that reaches down to 60 Hz to enable fullrange applications. The 12" woofer is slanted inside the housing, giving the cabinet a lean, unobtrusive look.

- **12" neodymium woofer**
- **Fullrange capability from 60Hz up**



### **Accurate and awesomely efficient midrange response**

The DVA T12's two 6.5" neodymium midrange are placed close together to maximize coherent coupling and response for those critical midrange frequencies. The speaker resides in a sealed basket to optimize the displacement volume. This makes the midrange even more responsive.

With a high BL factor, it reacts far faster to transients and renders each attack with awesome accuracy. Both 6.5" midrange are equipped with an optimized phase plug and feed into a frontloaded horn to achieve a uniform coverage pattern.

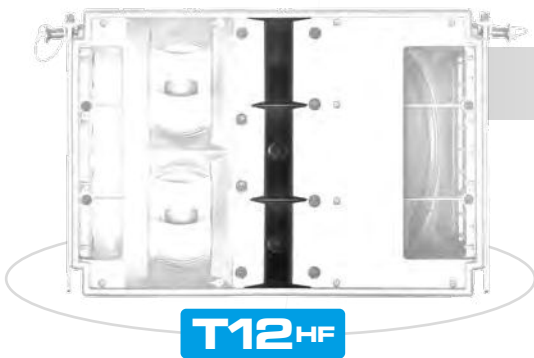

### **High-definition top end**

The 1" neodymium HF drivers feature 1.4" Mylar diaphragms. Exceptionally light and responsive, they deliver richly detailed signals with remarkably linear frequency response. Specially developed for use in line arrays, these ultra compact drivers may be deployed in very close proximity to one another. This is essential to minimize interference in such arrays.

The DVA T12 is loaded with three HF drivers tuned specifically for the custom designed array horn. This combination maximizes the coupling of the drivers' outputs and extends the range of the HF signal.

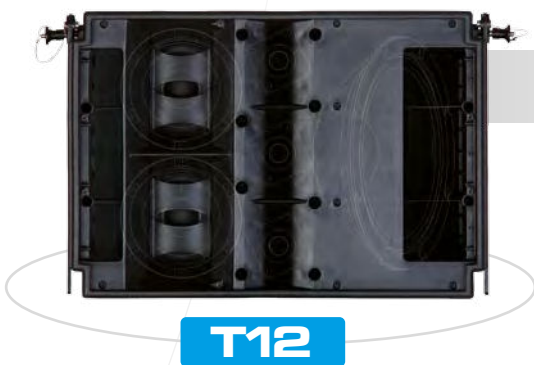

### **Consistent coverage pattern**

The DVA T12 features constant directivity horns, HF drivers, and midrange speakers optimized to deliver a uniform 100°-by-10° coverage pattern.

The DVA makes the most of two acoustical effects to help distribute SPL evenly. One is the vector addition of individual horns' output, with the other being cylindrical wave formation. The coverage pattern may be adapted to suit the sound reinforcement application by varying the length of the array and adjusting the splay between individual components.

- **Uniform 100°-by-10° coverage pattern**
- **Evenly distributed SPL**

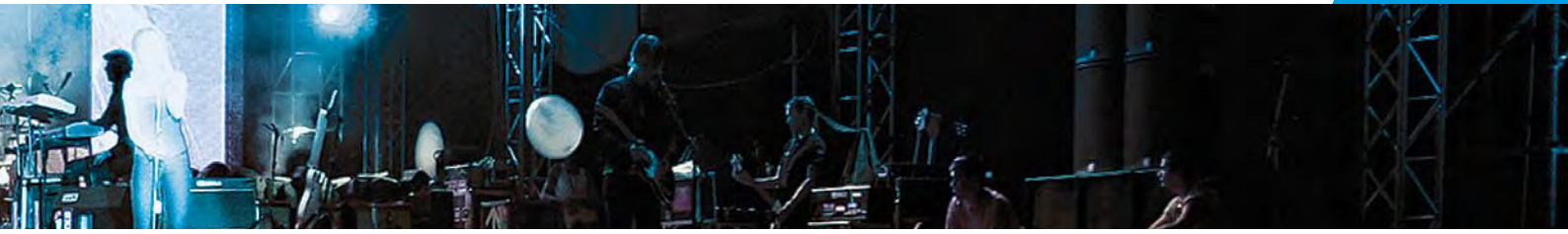

## Ground stacks

DRK-10 and DRK-20 harnesses can also serve to stack cabinets on the ground when rigging points are unavailable or the ceiling is too low. A special bracket adjusts the inclination down to 7.5°. The DRK-10/20 fits perfectly on an upright DVA S30 subwoofer. Equipped with two receptacles for quick-release pins, it is readily attached without tools. The DVA S30 subwoofer sports two 18" speakers, a bass reflex horn, a 3000W power amp, and an internal DSP. (To learn more about it, see the chapter entitled Active Subwoofer).

### ■ Line array benefits in ground-stacked configurations



### Compatible with DVA T8 units:

DVA T12 and DVA T8 series housings and rigging hardware are compatible. This means DVA T8 units may be flown right below a T12 array for use as down-fills in large PA systems.

### ■ Compatible DVA T8's may serve as far-fill extensions

## Power Supply

The PFC switched-mode power supply allows up to four DVA T12 units to be connected to one phase. When connecting large systems (up to 12 units), we recommend splitting up the power feed using a 16ACEKON adapter, tapped and spliced to feed three weatherproofed Power-Con connectors.

