

DIMENSIONS

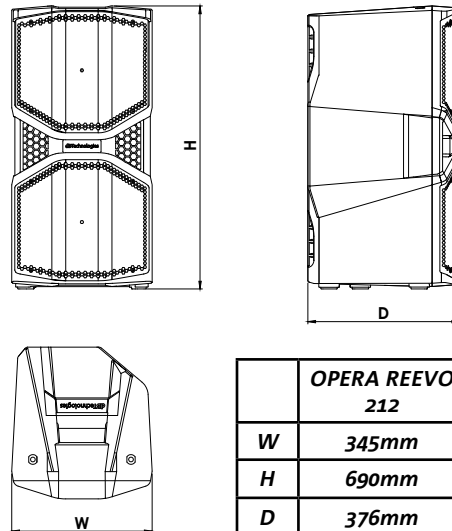

	OPERA REEVO 212	OPERA REEVO 210
W	345mm	300mm
H	690mm	604mm
D	376mm	324mm



PACKAGE CONTENTS

- The box contains:
- n.1 OPERA REEVO speaker
 - n.1 mains cable
 - n.1 fuse
 - n.1 transport cover
 - This quick start and warranty documentation

MAIN FEATURES

- Unique design
- Impressive sound pressure
- Compact size
- Quick installation
- Multiple configuration options

DESCRIPTION

OPERA REEVO is the new active speaker series designed for small live contests. The acoustic design combines coaxial mid-high driver with neodymium woofers and delivers very high SPL in a compact size thanks to the powerful Digipro amplifier. The series consists in two models, OPERA REEVO 210 (10" neodymium woofer) and OPERA REEVO 212 (12" neodymium woofer), that can be easily adapted to multiple situations thanks to the different possible mounting configurations. The DSP on board allows quick equalization between different presets.

Speaker Type	Quasi 3-Ways Active Loudspeaker	Quasi 3-Ways Active Loudspeaker
Frequency Response [-6dB]	52 Hz - 19.2 kHz	60 Hz - 19.2 kHz
Usable Bandwidth [-10dB]	48 Hz - 20 kHz	54 Hz - 20 kHz
Max SPL (1 m)	133 dB	132.5 dB
Directivity (HxV)	100° x 80°	100° x 90°
HF	1 - 1.75" v.c.	1 - 1.75" v.c.
LF	2x 12" neodymium, 2.5" v.c.	2x 10" neodymium, 2.5" v.c.
Crossover Frequency	1260 Hz - 24 dB/oct	1260 Hz - 24 dB/oct
Amplifier	Digipro G2 1050 W RMS Class-D	
Power Supply	VDE	
Cooling	Passive (convection)	
Operating Range	220-240V~ (50-60Hz)/110-120V~ (50-60 Hz)	
Limiter	Peak, RMS, Thermal	
Processing	FIR Linear Phase Filters	
Controller	28/56 bit DSP	
AD/DA Converter	24 bit/48 kHz	
Controls	1x Level knob 1x Preset button 2x System LED 2x Preset LED	
Signal Input	1 x combo XLR/jack balanced	
Signal Output	1x XLR balanced	
Housing	Polypropylene with external supports	
Pole mount	36mm	
Rigging Points	3 (M10)	
Dimensions (WxHxD)	345x690x376 mm (13.6x27.2x14.8 in)	300x604x324 mm (11.8x23.8x12.8 in)
Weight	20.4 Kg (45 lbs.)	17.2 Kg (38 lbs.)

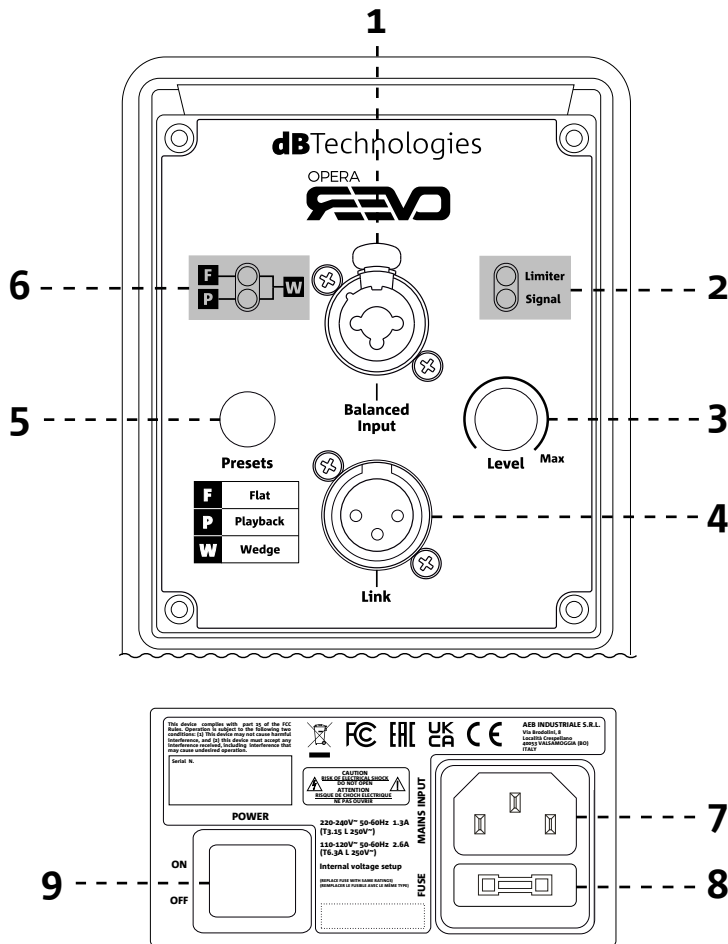

I/O and Control panel

The amplifier of OPERA REEVO is controlled by a state-of-the-art DSP. All the connections and controls are in the amplifier control panel.

- 1- **Balanced audio input**
- 2- **Status LEDs (Limiter, Signal)**
- 3- **Level knob**
- 4- **Link output**
- 5- **Presets button**
- 6- **Presets LED**
- 7- **Mains input**
- 8- **Mains fuse**
- 9- **On/Off switch**

Setup, turn on and I/O settings

Connect first the audio source to the Balanced Input (1) using an XLR or jack TRS balanced cable. Use Link Output (4) to connect other speakers in daisy chain. Connect the included VDE mains cable to the mains input (7) and push the On/Off switch (9) to power up the speaker. Adjust the audio level and choose the equalization preset (5) depending on the application.

POWER SUPPLY SPECIFICATIONS (POWER ABSORPTION)

Draw at 1/8 of full power in average use conditions (*): 1.6 A (220-240V~) - 2.6 A (100-120V~)

Draw at 1/3 of full power in average use conditions (**): 3.1 A (220-240V~) - 5.2 A (100-120V~)

Power absorption with speaker turned on without signal (idle): 31 W (220-240V~) - 31 W (100-120V~)

**INSTALLER NOTES: The values refer to 1/8 of full power, in average operating conditions (music program with infrequent or no clipping). It is recommended to consider them the minimum sizing values, for any type of configuration.*

***INSTALLER NOTES: The values refer to 1/3 of full power, in heavy operating conditions (music program with frequent clipping or activation of the limiter). We recommend sizing according to these values in case of professional installations and tours.*

HANDLES

OPERA REEVO are equipped with two handles for easy transport (A).

MECHANICAL FIXING POINT

OPERA REEVO can be installed in different configurations. On the top and on the back (B) the user can find mechanical fixing points for flyable use; the loudspeakers are equipped with a pole mount on the bottom (C).

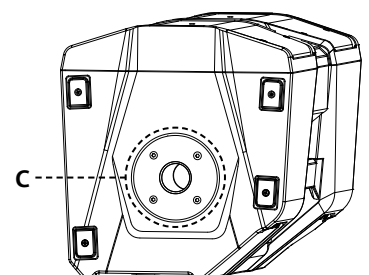
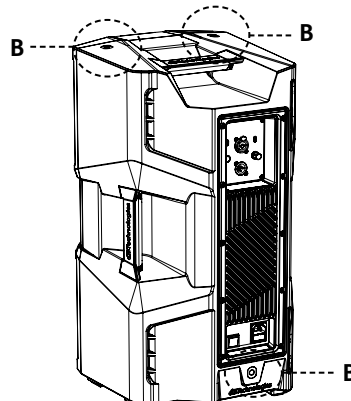
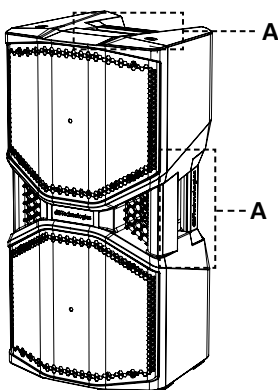

CONFIGURATIONS

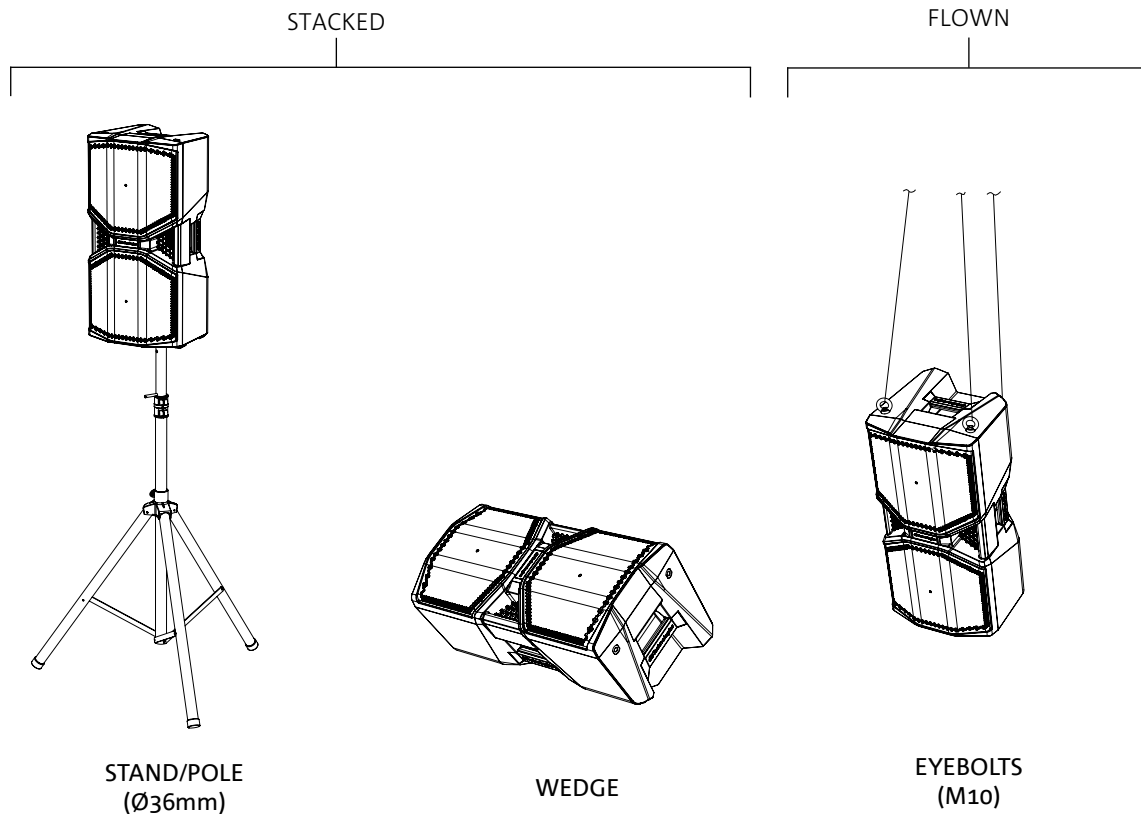

IMPORTANT NOTES AND WARNINGS

EMI CLASSIFICATION

According to the standards EN 55032 and 55035 this is a Class A equipment, designed and suitable to operate for professional use.

Warning: This equipment is compliant with Class A of CISPR 32. In a residential environment this equipment may cause radio interference

FCC CLASS A STATEMENT

Any changes or modifications not expressly approved by the party responsible for compliance could void the user's authority to operate the equipment.

This equipment has been tested and found to comply with the limits for a Class A digital device, pursuant to part 15 of the FCC Rules.

These limits are designed to provide reasonable protection against harmful interference when the equipment is operated in a commercial environment.

This equipment generates, uses, and can radiate radio frequency energy and, if not installed and used in accordance with the instruction manual, may cause harmful interference to radio communications. Operation of this equipment in a residential area is likely to cause harmful interference in which case the user will be required to correct the interference at his own expense.

WARNING: Make sure that the loudspeaker is securely installed in a stable position to avoid any injuries or damages to persons or properties. For safety reasons do not place one loudspeaker on top of another without proper fastening systems. Before hanging the loudspeaker check all the components for damages, deformations, missing or damaged parts that may compromise safety during installation. If you use the loudspeakers outdoor avoid spots exposed to bad weather conditions. Contact dBTechnologies for accessories to be used with the speakers. dBTechnologies will not accept any responsibility for damages caused by inappropriate accessories or additional devices.

Features, specification and appearance of products are subject to change without notice.

dBTechnologies reserves the right to make changes or improvements in design or manufacturing without assuming any obligation to change or improve products previously manufactured.

IMPORTANT SAFETY INSTRUCCIONES

1. Read these instructions
2. Keep these instructions.
3. Heed all warnings.
4. Follow all instructions.
5. Do not use this apparatus near water.
6. Clean only with dry cloth.
7. Do not block any ventilation openings. Install in accordance with the manufacturer's instructions.
8. Do not install near any heat sources such as radiators, heat registers, stoves, or other apparatus (including amplifiers) that produce heat.
9. Do not defeat the safety purpose of the polarized or grounding-type plug. A polarized plug has two blades with one wider than the other. A grounding type plug has two blades and a third grounding prong. The wide blade or the third prong are provided for your safety. If the provided plug does not fit into your outlet, consult an electrician for replacement of the obsolete outlet.
10. Protect the power cord from being walked on or pinched particularly at plugs, convenience receptacles, and the point where they exit from the apparatus.
11. Only use attachments/accessories specified by the manufacturer.
12. Use only with the cart, stand tripod, bracket, or table specified by the manufacturer, or sold with the apparatus. When a cart is used, use caution, when moving the cart/apparatus combination to avoid injury from tip-over.
13. Unplug this apparatus during lightning storms or when unused for long periods of time.
14. Refer all servicing to qualified service personnel. Servicing is required when the apparatus has been damaged in any way, such as power-supply cord or plug is damaged, liquid has been spilled or objects have fallen into the apparatus the apparatus has been exposed to rain or moisture, does not operate normally, or has been dropped.

ADDITIONAL SAFETY INSTRUCTIONS

- No naked flame sources, such as lighted candles, should be placed on the apparatus
- Do not use the apparatus in tropical climates

**WARNINGS!**

Only expert personnel may use the product and its accessories! To prevent hazards to people, animals and/or objects, make sure that the installation is stable and secure. Comply with the safety regulations and laws in force in the country in which you use the product. For safe use, periodically check that all parts are in good working condition before use. Only authorised personnel may carry out design, calculations, installation, testing and maintenance of professional flown or stacked audio systems. AEB Industriale shall not be liable for improper installation carried out without adequate safety measures.

Never suspend the speakers from the handles! Only use the accessories and configurations described in this manual, and proceed in accordance with the instructions given in the manuals for the accessories.

Do not obstruct the amplifier cooling fins at the back. In the event of overheating, the audio volume is gradually reduced until the module is thermally stable. The level is automatically restored on reaching the correct operating temperature.

Do not attempt to open the amplifier.

In the event of malfunction, immediately turn off the power, disconnect the unit from the mains and contact an authorised service centre.

Only use the power cable provided.

Do not use the monitor for a prolonged period with the limiter LED steadily lit or flashing as this indicates operation under stress with excessive distortion.

Check periodically the integrity and the functionality of the accessories and the technical equipments for a safe installation. User should never apply a load that exceeds the working load limits of any rigging components or equipment here presented. Design, calculation, installation, testing and maintenance of suspension and stack systems for audio equipment must be performed only by qualified and authorized personnel. AEB Industriale s.r.l. denies any and all responsibility for improper installations, in the absence of safety requirements.

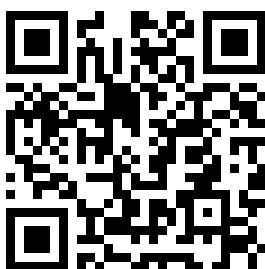
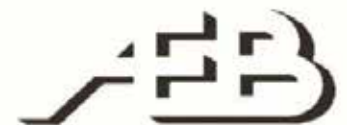

*Scan with your
QR Reader App
to download the
complete User
Manual.*

A.E.B. Industriale Srl
Via Brodolini, 8
Località Crespellano
40053 VALSAMOGGIA
BOLOGNA (ITALIA)
Tel. +39 051 969870
Fax +39 051 969725

www.dbtechnologies.com
info@dbtechnologies-aeb.com