

MINI G2

Quick start user manual

Section 1

The warnings in this manual must be observed together with the "USER MANUAL - Section 2".

Le avvertenze nel presente manuale devono essere osservate congiuntamente al "MANUALE D'USO - Sezione 2".

Die Warnungen in diesem Handbuch müssen in Verbindung mit der "BEDIENUNGSANLEITUNG - Abschnitt 2" beobachtet werden".

Les avertissements spécifiés dans ce manuel doivent être respectés ainsi que les "CARACTERISTIQUES TECHNIQUES - Section 2".

Las advertencias del presente manual se deben tener en cuenta conjuntamente con las del "MANUAL DEL USUARIO" - Sección 2".

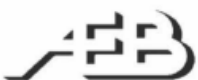

A.E.B. Industriale Srl Via Brodolini, 8 Località Crespellano 40053 VALSAMOGGIA BOLOGNA (ITALIA)
Tel +39 051 969870 Fax +39 051 969725 www.dbtechnologies.com info@dbtechnologies-aeb.com



Thank you for choosing a dBTechnologies Product!

DVA MINI G2 is an active line array module, equipped with two 0.75" exit neodymium compression driver (1" voice coil) and two 6.5" neodymium woofers (1.75" voice coil). The full-range acoustical design includes integrated horns and double phase plugs, in order to reach the best coherence in line-array configuration. The mechanical design allows an easy, accurate and quick installation in flown or stack use (3 points fast rigging system). The powerful DIGIPRO® G3 amplifier section, capable of handling up to 400 W (RMS power), is controlled by a DSP, which can perform a detailed customization of the output sound of the speaker. In particular, thanks to the DSP rotary interface, it is possible to accurately tune the line-array configuration coverage, taking advantage of FIR filter technology. In addition, the integrated RDNET connections are useful for a remote in-depth line-array control and configuration (dBTechnologies COMPOSER and AURORA NET softwares).

Check the site www.dbtechnologies.com for the complete user manual!

I) Unpacking

The box contains:

N°1 DVA MINI G2

N°1 100-120 V FUSE

This quick start and warranty documentation

II) Easy installation

DVA MINI G2 can be installed in different configurations (flown or stacked), thanks to the 3 points fast rigging system and a complete set of professional accessories (not included, see chapter III). Please note that for the mechanical safety check the software dBTechnologies Composer software must be used (see also chapter V).

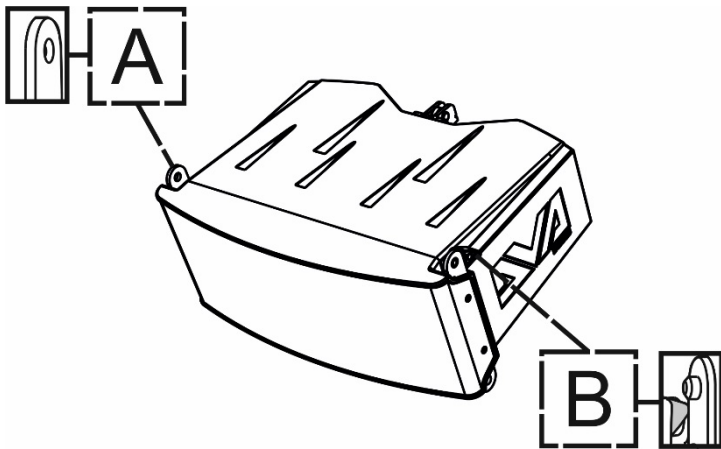
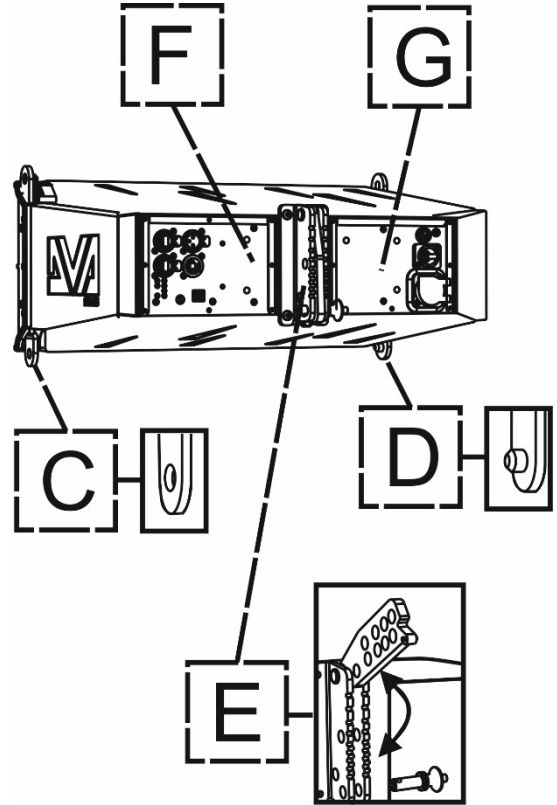
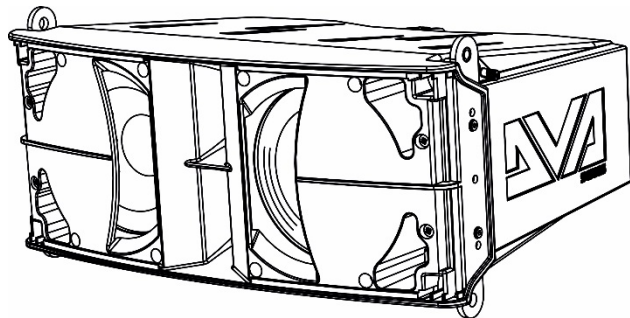

A – upper bracket (with hole)

B – upper bracket (with integrated pin)

The B bracket is equipped with a SAFETY LOCK (see the detail in the side picture).

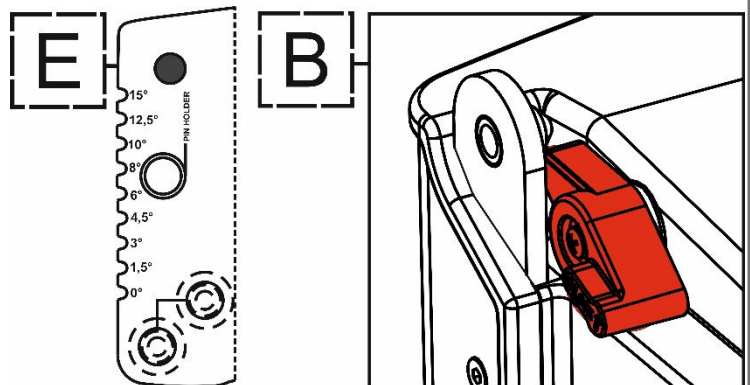

C – lower bracket (with hole)

D – lower bracket (with integrated pin)

E – rear bracket with joint and quick release pin

F – audio/network I/O and control section

G – power supply amplifier section

The E rear bracket shows the admitted tilted angles between line-array modules.

FRONT SIDE MOUNTING

Put two DVA MINI G2 modules (X, Y) one on top of the other. On the front side, the integrated pin of D bracket must be inserted in the hole of the A one, as shown below.

The same happens with the integrated pin of B, which is inserted in the hole of C bracket.

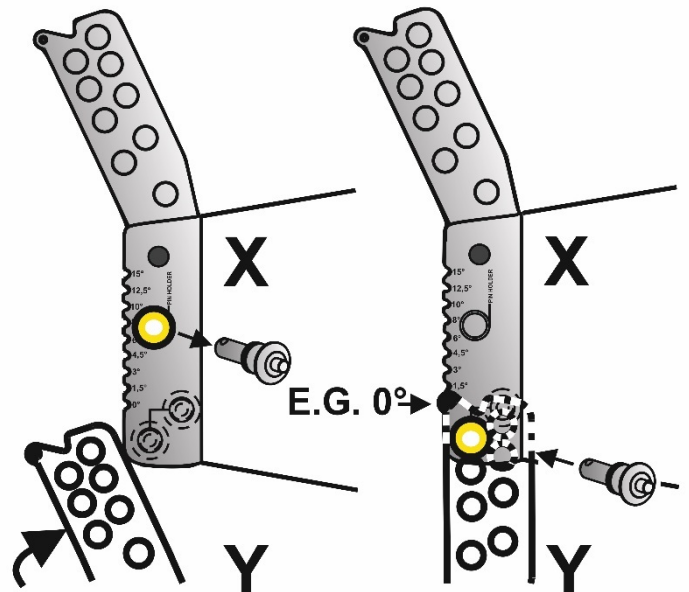
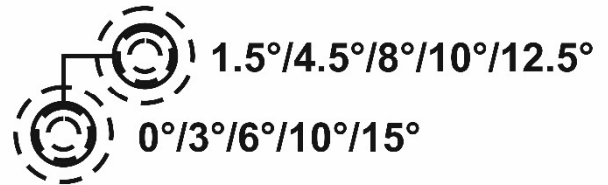
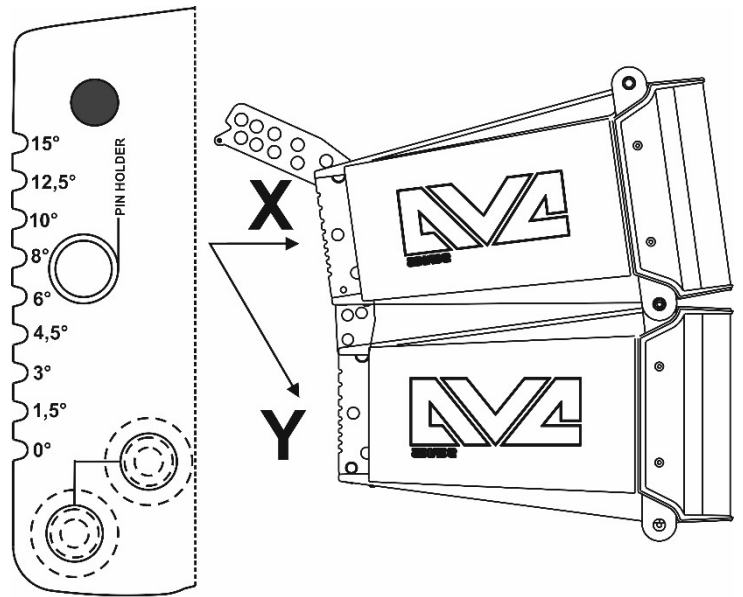
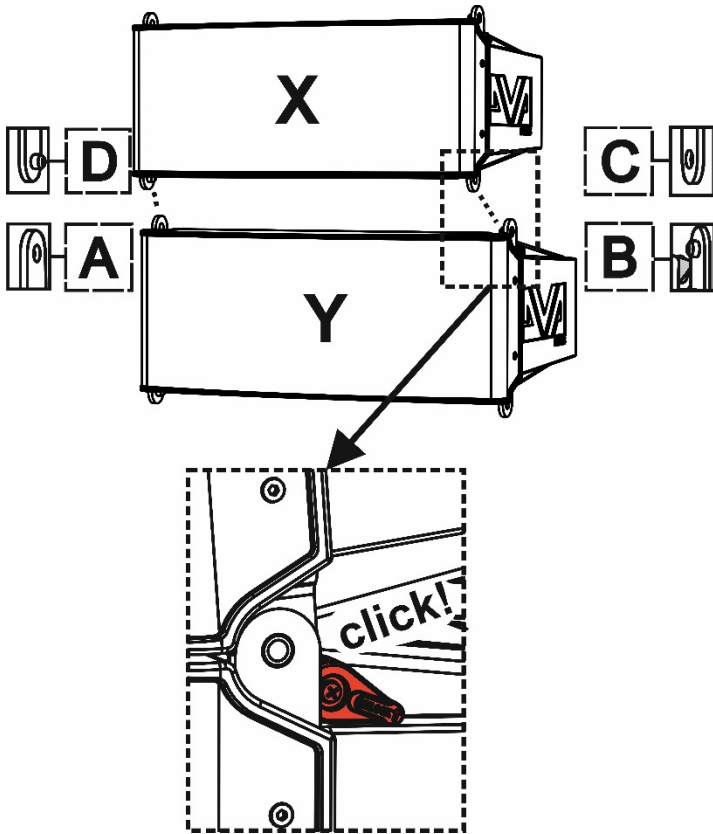

Please note that the SAFETY LOCK, once it is necessary to disassemble two modules, must be pulled up to unlock them.

REAR SIDE MOUNTING

Extract the rear pin from the PIN HOLDER position in E bracket (in both the X, Y modules).

Choose the desired tilt angle among the admitted ones, shown in the side picture.

Insert the joint of Y module, aligning the desired hole, in the E bracket of the X module.

Insert the pin as shown in the example to lock this position.

The upper point of the joint displays the final angle tilt as illustrated.



CHECK PERIODICALLY THE INTEGRITY AND THE FUNCTIONALITY OF THE ENCLOSURE, OF THE PINS AND OF THE BRACKETS, FOR A SAFE INSTALLATION. MAKE SURE THAT THE PINS SECURE PROPERLY THE MODULES AND THAT THEY ARE FULLY LOCKED.

III) DRK-M5 features and main accessories

For an easy setup are available among others: a professional fly-bar (**DRK-M5**) for flown installation, a cart (**DT-8-MINI**) for a quick and safe transport, a rain cover, and accessories specifically designed for stacked mounting. Please note that DVA MINI G2 can also be directly mounted in line array configuration under the DVA MS12 subwoofer (see the related complete manual for further information).

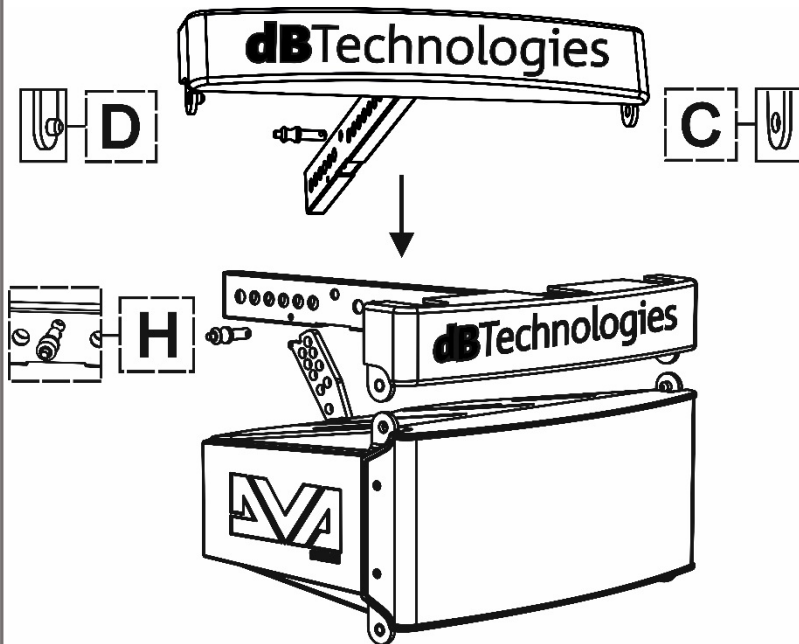

NAME	TYPE
DRK-M5	FLYBAR
DT-8-MINI	CART
DSA-M2A	POLE MOUNT ADAPTER
DSF-M2	ON SUBWOOFER ADAPTER
RC-M2	RAIN COVER



CHECK PERIODICALLY THE INTEGRITY AND THE FUNCTIONALITY OF THE ACCESSORIES AND OF THE TECHNICAL EQUIPMENTS FOR A SAFE INSTALLATION. USER SHOULD NEVER APPLY A LOAD THAT EXCEEDS THE WORKING LOAD LIMITS OF ANY RIGGING COMPONENTS OR EQUIPMENT HERE PRESENTED. DESIGN, CALCULATION, INSTALLATION, TESTING AND MAINTAINANCE OF SUSPENSION AND STACK SYSTEMS FOR AUDIO EQUIPMENT MUST BE PERFORMED ONLY BY QUALIFIED AND AUTHORIZED PERSONNEL. AEB INDUSTRIALE S.R.L. DENIES ANY AND ALL RESPONSIBILITY FOR IMPROPER INSTALLATIONS, IN THE ABSENCE OF SAFETY REQUIREMENTS.

The **DRK-M5** fly-bar is an example of the same 3 points rigging system strategy.

As shown in the picture, in the front side, it is equipped with the same **C** and **D** brackets of a DVA MINI G2, so the front side mounting is the same as seen between two line-array modules.

In the rear side, the **H** hole and pin allows the desired tilt selection.

Due to the various possibilities of installation (positive/negative angles, for example) please refer to the complete manual of the fly-bar for the complete mounting sequence and for further details.

A list of the available accessories is shown in the following table. Please refer to their single instructions.

IV) First switch on for line-array setup

The DIGIPRO G3® amplifier of DVA MINI G2 is controlled by a powerful DSP. All the connections and controls are in the rear amplifier control panel:

- 1 – Balanced audio input and output link
- 2 – DSP preset rotary switch
- 3 – RDNNet Data In / Data out
- 4 – USB port for firmware updating
- 5 – Status LEDs (Limiter, Signal, Status, ON)
- 6 – Auto-range Mains Input
- 7 – Mains link output
- 8 – Mains fuse

WARNING

The fuse is factory set for 220-240V~ operation.

If it is necessary to change the fuse to 100-120V~ range:

1. Turn off the power and disconnect the speaker from any cable.
2. Wait 5 minutes.
3. Substitute the fuse with the correct one supplied.

a) Once you have properly set up the mechanical line-array configuration (see also the DVA MINI G2 complete user manual and accessories instructions for further information), connect the audio input (1) of the first module of the array. Then connect the useful link audio output (1) to other DVA MINI G2 modules, for the connection of all the line-array elements.

b) The configuration can be set and modified by the user of the local DSP Preset (2) rotary or remote controlled (RDNNet Control 2 or RDNNet Control 8) using softwares (dBTechnologies AURORA NET). For further information see the chapter 5.

The DSP preset is divided into 3 main operation areas:

- 1) FRONT FILL usage
- 2) up to 6 boxes (HF1/HF2/HF3)
- 3) more than 6 boxes (HF1/HF2/HF3)

- HF1 – short distance coverage setup
- HF2 – medium distance coverage setup
- HF3 – far distance coverage setup

c) Connect the power link output (7) of the first module to the mains input (6) of a second DVA MINI G2 module of the line-array, and so on, in order to link the power supply between all the elements. The maximum linkable rated power and current depends on the first module connection (type of cable, type of connector used). The plate data give information about the entire linked line-array system. The maximum number of modules for each power daisy chain connection [mains input + mains link] is: 1+9 DVA MINI G2s** at 220-240V~, and 1+7 DVA MINI G2s** at 100-120V~ (for further information see Technical Data).

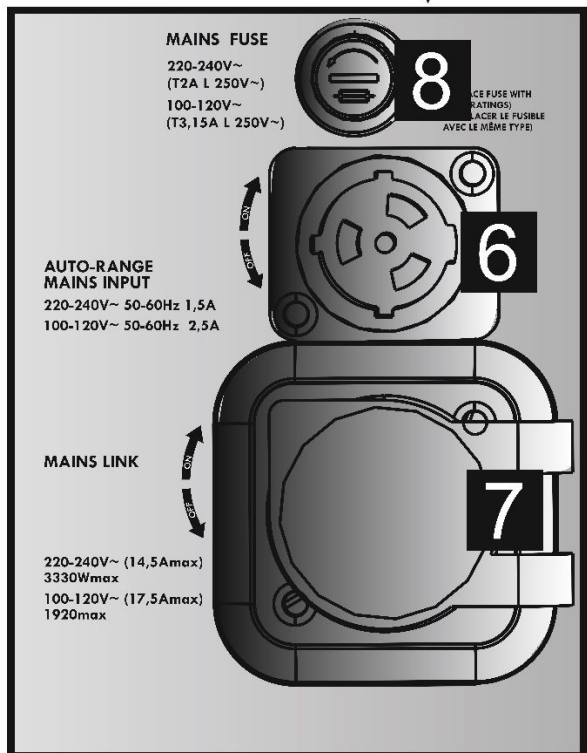
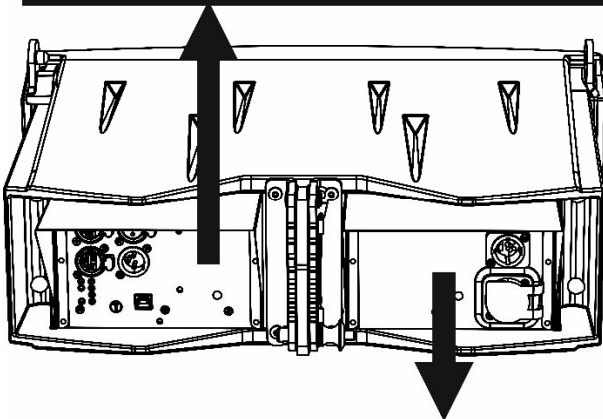
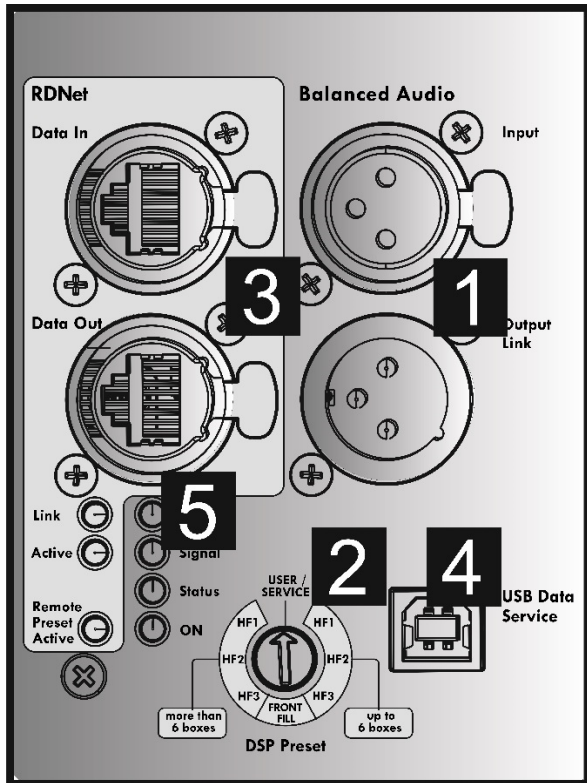

d) Connect the power supply (6) to the first module. The related “Ready” LED (5) turns on, signaling the proper power connection. The “Signal” LED (5) start blinking at the presence of audio signal (greater than -20dBu). Avoid audio distortion conditions, potentially signaled by the “Limiter” LED.

e) In case of remote control, connect the proper Data Input (3) of the first module of the line-array to the hardware remote controller (RDNet Control 2 or RDNet Control 8) with cables equipped with etherCON connectors. Then connect the Data Output (3) of the first module to the Data Input (3) of the second one, and so on. When the RDNet network is on and it has recognized the connected device, the LED “Link” is on. The other LED “Active” start blinking when there is the presence of data transmission, the “Remote Preset Active” advise that all the local controls set on the amplifier panel (level, DSP presets, etc.) are by-passed and controlled remotely by RDNet. See also RDNet Control 2 and RDNet Control 8 user manuals for further information.

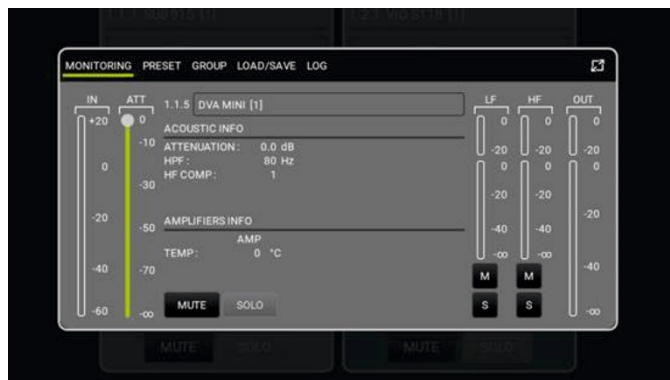

 **LAST SETTINGS STORED ON DVA MINI G2 (USING DBTECHNOLOGIES AURORA NET SOFTWARE), CAN BE RECALLED LATER ON THE SPEAKER, WITHOUT RDNET REMOTE CONTROL: SIMPLY TURN THE ROTARY “DSP Preset” ON “SERVICE/USER” POSITION.**

V) Softwares (dBTechnologies AURORA NET and dBTechnologies Composer)

DVA MINI G2 can be fully remote controlled via RDNet. The connection details have been illustrated in the chapter IV (“e” point). In remote control mode, the use of free professional software AURORA NET, developed by dBTechnologies, allows a complete system management. Furthermore, dBTechnologies Composer, and EASE (third-party software) are here presented.

- dBTechnologies AURORA NET

It allows a complete remote control and a full real-time monitoring in various scenarios. For example, the user can monitor and change different parameters while the entire system is sounding. It can also offer a deeper loudspeaker control than the simple rear amplifier panel rotary. It can be downloaded for free from the official site: www.dbtechnologies.com/EN/Downloads.aspx Check always for software updates!

- dBTechnologies Composer

The software dBTechnologies Composer is necessary to check the mechanical safety of the system and for the sound behavior predictions of the system. It has been developed to optimize complex acoustical settings like line-array alignment.

- EASE (third-party software)

The GLL file to be used in EASE software is downloadable for free from the official site: www.dbtechnologies.com/EN/Downloads.aspx.

Check the complete user manual on www.dbtechnologies.com for further information about the system and available accessories.

Scarica il manuale completo da www.dbtechnologies.com per ogni ulteriore informazione sul sistema e sugli accessori disponibili.

Für weitere Informationen und verfügbares Zubehör lesen sie bitte die vollständige Bedienungsanleitung unter www.dbtechnologies.de.

Vérifiez le manuel de l'utilisateur complet sur www.dbtechnologies.com pour des informations complémentaires du système et des accessoires disponibles.

Compruebe el manual de usuario completo sobre www.dbtechnologies.com para la información adicional sobre el sistema y accesorios disponibles.

Technical Data

Speaker Type: 2-way propylene line-array element

Acoustical data

Usable Bandwidth [-10 dB]: 75 - 20000 Hz

Frequency Response [-6 dB]: 80 - 19000 Hz

Max SPL (1 m): 131 dB

HF compression driver: (2x) 0.75" Exit, Neodymium

HF voice coil: 1"

LF: (2x) 6.5", Neodymium

LF Voice Coil: 1.75"

Crossover frequency: 1900 Hz (24 dB/oct)

FIR filters: yes

Horizontal dispersion ([-6dB] 80 – 19000 Hz): 100°

Vertical dispersion: varies on number of modules and configurations

Amplifier

Amp Technology: Digipro® G3 - Autorange

Amp Class: Class-D

RMS Power: 400 W

Peak Power: 800 W

Cooling: Passive (convection)

Operating range: 220-240V~ (50-60Hz)/100-120V~ (50-60 Hz)

Processor

Controller: DSP, 28/56 bit

AD/DA conversion: 48 kHz 24 bit

Limiter: Dual Active Peak, RMS, Thermal

Controls: DSP presets

Advanced DSP function: Linear Phase FIR filters

Rotary presets: 1 Rotary BCD 8 positions for line-array configuration (DSP preset)

Input / Output

Mains connections: PowerCON® TRUE1 In / Link

Maximum number of modules for each daisy chain power connection [mains input + mains link]: 1 + 9 DVA MINI G2** (220-240V~), 1 + 7 DVA MINI G2** (100-120V~)

Signal Input: (Balanced) 1x XLR IN

Signal Out: (Balanced) 1 x XLR link OUT

RDNET connectors: Data In / Data Out

USB connector: USB B-type (for SERVICE DATA)

Mechanics

Housing: Polypropylene cabinet

Grille: CNC machined full metal grille

Rigging points: 3 (Easy Rigging)

Width: 460 mm (18.1 in)

Height: 190 mm (7.5 in)

Depth: 345 mm (13.6 in)

Weight: 8.4 kg (18.5 lbs.)



Scan with your QR Reader App to download the complete User Manual

Download the complete user manual on:

www.dbtechnologies.com/EN/Downloads.aspx

EMI CLASSIFICATION

According to the standards EN 55032 and 55035 this is a class B equipment, designed and suitable to operate in residential environments.

FCC CLASS B STATEMENT ACCORDING TO TITLE 47, PART 15, SUBPART B, §15.105

This equipment has been tested and found to comply with the limits for a Class B digital device, pursuant to part 15 of the FCC Rules.

These limits are designed to provide reasonable protection against harmful interference in a residential installation.

This equipment generates, uses and can radiate radio frequency energy and, if not installed and used in accordance with the instructions, may cause harmful interference to radio communications.

However, there is no guarantee that interference will not occur in a particular installation. If this equipment does cause harmful interference to radio or television reception, which can be determined by turning the equipment off and on, the user is encouraged to try to correct the interference by one or more of the following measures:

1. Reorient or relocate the receiving antenna.
2. Increase the separation between the equipment and receiver.
3. Connect the equipment into an outlet on a circuit different from that to which the receiver is connected.
4. Consult the dealer or an experienced radio/TV technician for help.

Changes or modifications not expressly approved by the party responsible for compliance could void the user's authority to operate the equipment.

WARNING: Make sure that the loudspeaker is securely installed in a stable position to avoid any injuries or damages to persons or properties. For safety reasons do not place one loudspeaker on top of another without proper fastening systems. Before hanging the loudspeaker check all the components for damages, deformations, missing or damaged parts that may compromise safety during installation. If you use the loudspeakers outdoor avoid spots exposed to bad weather conditions.

Contact dB Technologies for accessories to be used with speakers. dBTechnologies will not accept any responsibility for damages caused by inappropriate accessories or additional devices.

Features, specification and appearance of products are subject to change without notice. dBTechnologies reserves the right to make changes or improvements in design or manufacturing without assuming any obligation to change or improve products previously manufactured.

POWER SUPPLY SPECIFICATIONS (POWER ABSORPTION)

Draw at 1/8 of full power in average use conditions (*): 0.6 A (220-240V~) - 1.1 A (100-120V~)

Draw at 1/3 of full power in maximum use conditions (**): 1.5 A (220-240V~) - 2.5 A (100-120V~)

Power absorption with speaker turned on without signal (idle): 15 W

* INSTALLER NOTES: The values refer to 1/8 of full power, in average operating conditions (music program with infrequent or no clipping). It is recommended to consider them the minimum sizing values for any type of configuration.

** INSTALLER NOTES: The values refer to 1/3 of full power, in heavy operating conditions (music program with frequent clipping or activation of the limiter). We recommend sizing according to these values in case of professional installations and tours.