

VIO W15T

Active 2-way Coaxial Stage monitor

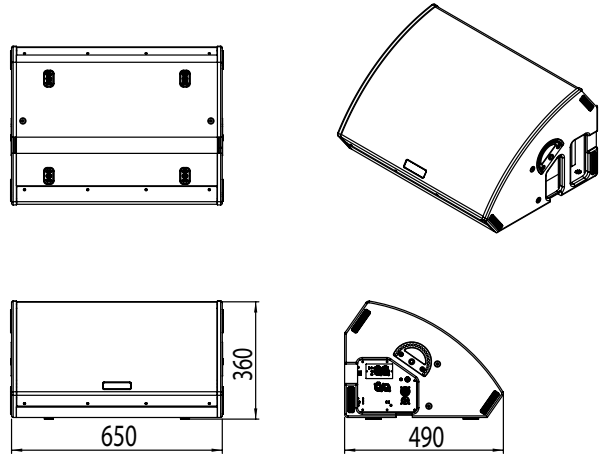

MAIN FEATURES

- Neodymium Transducers
- 1600w Rms Class-D Amplifier
- Rotatable Horn
- Advanced Dsp Featuring Linear Phase Fir Filters
- Full Range Smps With Pfc
- Modular Slot For Network And Digital Audio Expansion Cards (Rdnet Card Installed)
- Nfc™ + Front Led Identification System
- System Test For Quick Transducers Diagnostics
- Exclusive Front-Rear Grille Design

DESCRIPTION

With VIO W15T, the perfect touring wedge goes VIO. A powerful yet multiskilled stage monitor, able to keep up with VIO premium line array series on the most challenging live music stages. Making the most of its coaxial acoustic design, along with tour-grade amp technology and electronics, VIO W15T is the perfect stage companion for the most demanding musicians, while allowing for complete networkability and remote control in real-time.

ACCESSORIES

WB-VIOW15T

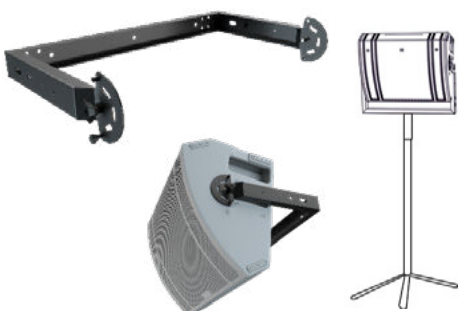

Bracket for VIO W15T, wall or pole mounted.

Speaker Type	2-Way Coaxial Active Stage Monitor
Usable Bandwidth [-10dB]	49 - 17,000 Hz
Frequency Response [-6dB]	55 - 16,000 Hz
Max SPL	137.5 dB
HF	1x 1.4", 3" v.c. - Coaxial Neodymium
LF	1 x 15", 3" v.c. - Coaxial Neodymium
Horizontal Directivity	80°
Vertical Directivity	60°
Amplifier	1600 W RMS Class-D Digipro® G4
Cooling	Convection, Internal fan
Power Supply	Full-range SMPS with PFC (100V~–240V~, 50-60Hz)
Controller	DSP 32 bit
AD/DA Converter	24 bit/96 kHz
Limiter	Dual Active Multiband Peak, RMS, Thermal
Processing (filters)	FIR Linear phase
Signal Input	1x XLR female, balanced 1x USB Data Service
Signal Output	1x XLR male, balanced
Power Socket	1x PowerCON TRUE1 In 1x PowerCON TRUE1 Out
Expansion card	RDNet Card (1x RJ45 IN 1x RJ45 Link) Dante Card [Optional]
Controls	1x Switch Flat/Service User 1x System Test Button 1x On-LED 1x Status-LED 1x Signal-LED 1x Limiter-LED
Special Features	NFC™ and Frontal LED Identification System 380V Resistant SMPS IPOS Intelligent Power-On Sequence Opto-isolated floating pre-amp System Test (transducers diagnostics)
Housing	Wooden Cabinet, Polyurea painting
Handles	1 (+ 2 recessions x side)
Rigging Points	2x M10 with rotatable points
Width x Height x Depth	650 x 360 x 490 mm (25.59 x 14.17 x 19.29 in)
Weight	29 kg (63.9 lbs)